

## DIN EN 10216-4



ICS 23.040.10; 77.140.75

Supersedes  
August 2002 edition.**Seamless steel tubes for pressure purposes – Technical delivery conditions**Part 4: Non-alloy and alloy steel tubes with specified low temperature properties  
(includes Amendment A1 : 2004)

English version of DIN EN 10216-4 : 2002 + A1 : 2004

Nahtlose Stahlrohre für Druckbeanspruchungen – Technische Lieferbedingungen – Teil 4: Rohre aus legierten und unlegierten Stählen mit festgelegten Eigenschaften bei tiefen Temperaturen (enthält Änderung A1 : 2004)

**European Standard EN 10216-4 : 2002 + A1 : 2004 has the status of a DIN Standard.***A comma is used as the decimal marker.***National foreword**

This standard has been prepared by ECISS/TC 29.

The responsible German body involved in the preparation of this standard was the *Normenausschuss Eisen und Stahl* (Steel and Iron Standards Committee), Technical Committee *Rohre aus warmfesten oder kaltzähen Stählen*.

DIN V 17006-100 is the standard corresponding to CEN Technical Report CR 10260 referred to in clause 2 of the EN.

**Amendments**

This standard differs from the August 2002 edition in that the specifications for inspection documents have been amended.

**Previous editions**

DIN 17173: 1985-02; DIN EN 10216-4: 2002-08.

**National Annex NA****Standard referred to**(and not included in **Normative references**)

DIN V 17006-100 Designation systems for steel – Additional symbols for steel names

Document comprises 30 pages.



ICS 23.040.10; 77.140.75

**English version**

**Seamless steel tubes for pressure purposes –  
Technical delivery conditions**

**Part 4: Non-alloy and alloy steel tubes with specified low temperature  
properties  
(includes Amendment A1 : 2004)**

Tubes sans soudure en acier pour  
service sous pression – Conditions  
techniques de livraison – Partie 4:  
Tubes en acier non allié avec caracté-  
ristiques spécifiées à basse tempé-  
rature (amendement A1 : 2004 inclus)

Nahtlose Stahlrohre für Druckbean-  
spruchungen – Technische Lieferbe-  
dingungen – Teil 4: Rohre aus legier-  
ten und unlegierten Stählen mit fest-  
gelegten Eigenschaften bei tiefen  
Temperaturen (enthält Änderung  
A1 : 2004)

This European Standard was approved by CEN on 2002-04-25 and Amendment A1 on 2004-01-02.

CEN members are bound to comply with the CEN/CENELEC Internal Regulations which stipulate the conditions for giving this European Standard the status of a national standard without any alteration.

Up-to-date lists and bibliographical references concerning such national standards may be obtained on application to the Management Centre or to any CEN member.

The European Standards exist in three official versions (English, French, German). A version in any other language made by translation under the responsibility of a CEN member into its own language and notified to the Management Centre has the same status as the official versions.

CEN members are the national standards bodies of Austria, Belgium, Cyprus, the Czech Republic, Denmark, Estonia, Finland, France, Germany, Greece, Hungary, Iceland, Ireland, Italy, Latvia, Lithuania, Luxembourg, Malta, the Netherlands, Norway, Poland, Portugal, Slovakia, Slovenia, Spain, Sweden, Switzerland, and the United Kingdom.

**CEN**

European Committee for Standardization  
Comité Européen de Normalisation  
Europäisches Komitee für Normung

**Management Centre: rue de Stassart 36, B-1050 Brussels**

## Contents

	Page
Foreword to EN 10216-4:2002.....	4
Foreword EN 10216-4:2002/A1:2004 .....	4
1 Scope .....	5
2 Normative references .....	5
3 Terms and definitions .....	6
4 Symbols .....	6
5 Classification and designation.....	7
5.1 Classification.....	7
5.2 Designation .....	7
6 Information to be supplied by the purchaser .....	7
6.1 Mandatory information.....	7
6.2 Options .....	8
6.3 Example of an order .....	8
7 Manufacturing process .....	8
7.1 Steelmaking process.....	8
7.2 Deoxidation process .....	8
7.3 Tube manufacture and delivery conditions .....	8
8 Requirements.....	10
8.1 General.....	10
8.2 Chemical composition .....	11
8.3 Mechanical properties.....	11
8.4 Appearance and internal soundness.....	15
8.5 Straightness .....	15
8.6 Preparation of ends .....	15
8.7 Dimensions, masses and tolerances.....	16
9 Inspection .....	20
9.1 Types of inspection .....	20
9.2 Inspection documents.....	20
9.3 Summary of inspection and testing.....	21
10 Sampling.....	21
10.1 Frequency of tests.....	21
10.2 Preparation of samples and test pieces .....	22
11 Test methods.....	23
11.1 Chemical analysis.....	23
11.2 Tensile test .....	23
11.3 Flattening test .....	23
11.4 Ring tensile test .....	24
11.5 Drift expanding test .....	24
11.6 Ring expanding test .....	25
11.7 Impact test.....	25
11.8 Leak tightness test .....	26
11.9 Dimensional inspection .....	26
11.10 Visual examination .....	26
11.11 Non-destructive testing.....	27
11.12 Material identification.....	27
11.13 Retests, sorting and reprocessing .....	27
12 Marking .....	27
12.1 Marking to be applied.....	27
12.2 Additional marking .....	28

<b>13</b>	<b>Protection .....</b>	<b>28</b>
	<b>Annex ZA (informative) Relationship between this European Standard and the Essential requirements of EU Directive 97/23/EC .....</b>	<b>29</b>
	<b>Bibliography.....</b>	<b>29</b>

## **Foreword to EN 10216-4:2002**

This document has been prepared by Technical Committee ECISS/TC 29, "Steel tubes and fittings for steel tubes", the Secretariat of which is held by UNI.

This document has been prepared under a mandate given to CEN by the European Commission and the European Free Trade Association, and supports essential requirements of the relevant EU Directive. For relationship with this EU Directive, see Annex ZA, which is an integral part of this document.

Other Parts of EN 10216 are:

- Part 2 Non-alloy and alloy steels tubes with specified elevated temperature properties
- Part 3 Alloy fine grain steel tubes
- Part 4 Non-alloy and alloy steel tubes with specified low temperature properties
- Part 5 Stainless steel tubes

Another European Standard series covering tubes for pressure purposes is:

- EN 10217 Welded steel tubes for pressure purposes

This European Standard shall be given the status of a national standard, either by publication of an identical text or by endorsement, at the latest by November 2002, and conflicting national standards shall be withdrawn at the latest by November 2002.

In accordance with to the CEN/CENELEC Internal Regulations, the national standards organizations of the following countries are bound to implement this European Standard:

Austria, Belgium, the Czech Republic, Denmark, Finland, France, Germany, Greece, Iceland, Ireland, Italy, Luxembourg, Malta, the Netherlands, Norway, Portugal, Spain, Sweden, Switzerland, and the United Kingdom.

## **Foreword EN 10216-4:2002/A1:2004**

This document has been prepared by Technical Committee ECISS /TC 29 "Steel tubes and fittings for steel tubes", the Secretariat of which is held by UNI.

This document has been prepared under a mandate given to CEN by the European Commission and the European Free Trade Association, and supports essential requirements of the relevant EU Directive. For relationship with this EU Directive, see Annex ZA, which is an integral part of this document.

In accordance with the CEN/CENELEC Internal Regulations, the national standards organizations of the following countries are bound to implement this European Standard:

Austria, Belgium, Cyprus, the Czech Republic, Denmark, Estonia, Finland, France, Germany, Greece, Hungary, Iceland, Ireland, Italy, Latvia, Lithuania, Luxembourg, Malta, the Netherlands, Norway, Poland, Portugal, Slovakia, Slovenia, Spain, Sweden, Switzerland, and the United Kingdom.

## 1 Scope

This Part of EN 10216 specifies technical delivery conditions, in two test categories, for seamless tubes of circular cross section, with specified low temperature properties, made of alloy or non-alloy steel.

## 2 Normative references

This European Standard incorporates, by date or undated reference, provisions from other publications. These normative references are cited at the appropriate places in the text and the publications are listed hereafter. For date references, subsequent amendments to or revisions of, any of these publications apply to this European Standard only when incorporated in it by amendment or revision. For undated references, the latest edition of the publication referred to applies (including amendments).

The requirements of this European Standard rule when they differ from those in the standards and documents referred to below:

EN 10002-1, *Metallic materials - Tensile testing - Part 1: Method of test (at ambient temperature)*.

EN 10020, *Definitions and classification of grades of steel*.

EN 10021, *General technical delivery requirements for steel and iron products*.

EN 10027-1, *Designation systems for steels - Part 1 : Steel names, principle symbols*.

EN 10027-2, *Designation systems for steels - Part 2 : Numerical systems*.

EN 10045-1, *Metallic materials - Charpy impact test - Part 1: Test method*.

EN 10052, *Vocabulary of heat treatment terms for ferrous products*.

EN 10204, *Metallic products - Types of inspection documents*.

ENV 10220, *Seamless and welded steel tubes - Dimensions and masses per unit length*

EN 10233, *Metallic materials - Tubes - Flattening test*.

EN 10234, *Metallic materials - Tubes - Drift expanding test*.

EN 10236, *Metallic materials - Tubes - Ring expanding test*.

EN 10237, *Metallic materials - Tubes - Ring tensile test*.

EN 10246-1, *Non-destructive testing of steel tubes - Part 1: Automatic electromagnetic testing of seamless and welded (except submerged arc welded) ferromagnetic steel tubes for verification of hydraulic leak tightness*.

EN 10246-5, *Non-destructive testing of steel tubes – Part 5: Automatic full peripheral magnetic transducer/flux leakage testing of seamless and welded (except submerged arc-welded) ferromagnetic steel tubes for the detection of longitudinal imperfections*.

EN 10246-6, *Non-destructive testing of steel tubes - Part 6: Automatic full peripheral ultrasonic testing of seamless steel tubes for the detection of transverse imperfections*.

EN 10246-7, *Non-destructive testing of steel tubes - Part 7: Automatic full peripheral ultrasonic testing of seamless and welded (except submerged arc welded) steel tubes for the detection of longitudinal imperfections*.

EN 10246-14, *Non-destructive testing of steel tubes - Part 14: Automatic ultrasonic testing of seamless and welded (except submerged arc welded) steel tubes for the detection of laminar imperfections*.

EN 10256, *Non-destructive testing of steel tubes - Qualification and competence of level 1 and level 2 NDT personnel.*

EN ISO 377, *Steel and steel products - Location and preparation of samples and test pieces for mechanical testing (ISO 377:1997)*

EN ISO 2566-1, *Steel - Conversion of elongation values – Part 1: Carbon and low-alloy steels (ISO 2566-1:1984)*

prEN 10168<sup>1)</sup> *Iron and steel products - Inspection documents - List of information and description*

prEN 10266<sup>1)</sup> *Steel tubes, fittings and structural hollow sections - Symbols and definition of terms for use in product standards*

ISO 14284, *Steel and iron - Sampling and preparation of samples for the determination of chemical composition*

CR 10260, *Designation systems for steel - Additional symbols*

CR 10261, *ECISS Information Circular IC 11 - Iron and steel - Review of available methods of chemical analysis.*

### 3 Terms and definitions

For the purposes of this Part of EN 10216, the terms and definitions given in EN 10020, EN 10021, EN 10052, prEN 10266 and the following apply:

#### 3.1 test category

Classification that indicates the extent and level of inspection and testing.

#### 3.2 employer

Organisation for which a person works on a regular basis.

NOTE The employer may be either the tube manufacturer or supplier or a third party organisation providing non-destructive testing (NDT) services.

### 4 Symbols

For the purposes of this Part of EN 10216, the symbols given prEN 10266 and the following apply:

— TC test category

---

1) In preparation. Until this document is published as a European Standard, the corresponding national standard(s) should be agreed at the time of ordering.



## 5 Classification and designation

### 5.1 Classification

In accordance with the classification system given in EN 10020, steel grades P 215NL, P 255QL and P265NL are classified as non-alloy quality steels and the other steel grades are classified as alloy special steels.

### 5.2 Designation

**5.2.1** For the tubes covered by this Part of EN 10216, the steel designation is to consist of:

— the number of this Part of EN 10216 ;

plus either:

— the steel name in accordance with EN 10027-1 and CR 10260;

or:

— the Material number allocated in accordance with EN 10027-2.

**5.2.2** The steel name of non-alloy steel grades is designated by:

— the capital letter P for 'pressure purposes';

— the indication of the specified minimum yield strength at room temperature, expressed in MPa (see table 4);

— the symbol of the heat treatment for the steel grade concerned (see table 1);

— the symbol L for 'low temperature'.

**5.2.3** The steel name of alloy-steel grades is designated by the chemical composition (see table 2) and the symbols for the heat treatment, where specified in column 1 and footnote a) of table 1

## 6 Information to be supplied by the purchaser

### 6.1 Mandatory information

The following information shall be supplied by the purchaser at the time of ordering:

- a) the quantity (mass or total length or number);
- b) the term "tube";
- c) the dimensions (outside diameter  $D$  and wall thickness  $T$ ) (see table 6);
- d) the designation of the steel grade in accordance with this Part of EN 10216 (see 5.2);
- e) the test category for non-alloy steel (see 9.3).

## 6.2 Options

A number of options are specified in this Part of EN 10216 and these are listed below. In the event that the purchaser does not indicate a wish to implement any of these options at the time of ordering, the tubes shall be supplied in accordance with the basic specification (see 6.1).

- 1) cold finishing (see 7.3.2);
- 2) restriction on copper and tin content (see table 2);
- 3) product analysis (see 8.2.2);
- 4) selection of leak tightness test method (see 8.4.2.1);
- 5) non-destructive testing for test category 2 tubes for detection of transverse imperfections (see 8.4.2.2);
- 6) non-destructive testing for test category 2 tubes for detection of laminar imperfections (see 8.4.2.2);
- 7) special ends preparation (see 8.6);
- 8) exact lengths (see 8.7.3);
- 9) the type of inspection document other than the standard document (see 9.2.1);
- 10) test pressure for hydrostatic leak tightness test (see 11.8.1);
- 11) wall thickness measurement away from the ends (see 11.9);
- 12) non-destructive test method (see 11.11.1);
- 13) additional marking (see 12.2);
- 14) protection (see 13);

## 6.3 Example of an order

50 t of seamless tube with an outside diameter of 168,3 mm, a wall thickness of 4,5 mm in accordance with EN 10216-4, made of steel grade P265NL, test category 1, with a 3.1.C inspection certificate in accordance with EN 10204:

50 t - Tube - 168,3 x 4,5 - EN 10216-4 - P265NL - TC1 - Option 9: 3.1.C

## 7 Manufacturing process

### 7.1 Steelmaking process

The steelmaking process is at the discretion of the manufacturer.

### 7.2 Deoxidation process

Steels shall be fully killed.

### 7.3 Tube manufacture and delivery conditions

**7.3.1** All NDT activities shall be carried out by qualified and competent level 1,2 and/or 3 personnel authorised to operate by the employer.

The qualification shall be in accordance with EN 10256 or, at least, equivalent to it.

It is recommended that the level 3 personnel be certified in accordance with EN 473 or, at least, an equivalent to it.

The operating authorisation issued by the employer shall be in accordance with a written procedure.

NDT operations shall be authorised by level 3 NDT individual approved by the employer.

EXAMPLE The definition of levels 1, 2 and 3 can be found in appropriate standards (e.g. EN 473 and EN 10256):

**7.3.2** The tubes shall be manufactured by a seamless process.

Unless option 1 is specified, the tubes may be either hot or cold finished at the discretion of the manufacturer. The terms “ hot finished “ and “ cold finished “ apply to the condition of the tube before it is heat treated in accordance with 7.3.3.

**Option 1:** *The tubes shall be cold finished before heat treatment.*

**7.3.3** The tubes shall be supplied in the relevant heat treatment conditions as specified in table 1.

**Table 1 — Delivery conditions**

Steel grade		Heat treatment <sup>a b</sup>	Normalising temperature °C	Tempering temperature °C	Quenching and tempering		
Name	Material number				Hardening temperature °C	Cooling medium <sup>c</sup>	Tempering temperature °C
P215NL	1.0451	+N	900 to 940	--	--	--	--
P255QL	1.0452	+QT	--	--	890 to 930	Water or oil	600 to 680
P265NL	1.0453	+N	880 to 940	--	--	--	--
26CrMo4-2	1.7219	+QT	--	--	830 to 860	Water or oil	600 to 680
11 MnNi5-3	1.6212	+N <sup>d</sup>	890 to 940	(580 to 640)	--	--	--
13 MnNi6-3	1.6217	+N <sup>d)</sup>	890 to 940	(580 to 640)	--	--	--
12Ni14	1.5637	+NT	830 to 880	580 to 640	--	--	--
		+QT	--	--	820 to 880	Water or oil	580 to 660
X12Ni5	1.5680	+NT	800 to 850	580 to 640	--	--	--
		+QT	--	--	800 to 850	Water or oil	580 to 660
X10Ni9	1.5682	+N+NT	880 to 915 + 775 to 805	565 to 605 <sup>e</sup>	-	--	--
		+QT <sup>f</sup>	(880 to 930)	--	770 to 820	water or oil	540 to 600

<sup>a</sup> N = Normalising ; QT = Quenching and tempering; NT = Normalising and tempering

<sup>b</sup> Where two types of heat treatment are specified for a steel grade, the application depends on wall thickness and *T/D* ratio. The decision is left to the manufacturer but shall be reported in the inspection document.

<sup>c</sup> When choosing the cooling medium the influence of other parameters, such as dimensions and quenching temperature, on properties and crack susceptibility should be taken into account. Other cooling media such as synthetic quenchants may also be used.

<sup>d</sup> Tempering can occasionally be necessary after normalising; The decision shall be at the discretion of the manufacturer but shall be stated to the customer at the time of ordering. Steel tubes treated in such a way shall be designated by the steel name supplemented by the symbol "+NT".

<sup>e</sup> Cooling at still air or accelerated cooling.

<sup>f</sup> An additional prenormalising treatment, in the temperature range indicated may be necessary for this grade. In such a case the manufacturer shall inform the purchaser.

## 8 Requirements

### 8.1 General

When supplied in a delivery condition indicated in clause 7.3 and inspected in accordance with clauses 9, 10 and 11, tubes shall conform to the requirements of this Part EN 10216.

In addition, the general technical delivery requirements specified in EN 10021 shall apply.

Tubes shall be suitable for hot and cold bending provided the bending is carried out in an appropriate manner.

## **8.2 Chemical composition**

### **8.2.1 Cast analysis**

The cast analysis reported by the steel producer shall apply and conform to with the requirements of table 2.

NOTE When welding tubes produced in accordance with this Part of EN 10216, account should be taken of the fact that the behaviour of the steel during and after welding is dependent not only on the steel, but also on the applied heat treatment and the conditions of preparing for and carrying out the welding.

### **8.2.2 Product analysis**

*Option 3: A product analysis for the tubes shall be supplied.*

Table 3 specifies the permissible deviations of the product analysis from the specified limits on cast analysis given in table 2 are specified in table 3.

## **8.3 Mechanical properties**

The mechanical properties of the tubes shall conform to the requirements in tables 4 and 5 and in 11.3 to 11.6.

Table 2 — Chemical composition (cast analysis) <sup>a</sup>, in % by mass

Steel grade		C	Si	Mn	P	S	Cr	Ni	Mo	Al <sub>total</sub> <sup>b</sup>	Cu <sup>c</sup>	Nb	Ti	V
Name	Material number				max	max				min	max	max	max	max
P215NL	1.0451	≤ 0,15	≤ 0,35	0,40 to 1,20	0,025	0,020	≤ 0,30	≤ 0,30	≤ 0,08	0,020	0,30	0,010	0,040	0,02
P255QL	1.0452	≤ 0,17	≤ 0,35	0,40 to 1,20	0,025	0,020	≤ 0,30	≤ 0,30	≤ 0,08	0,020	0,30	0,010	0,040	0,02
P265NL	1.0453	≤ 0,20	≤ 0,40	0,60 to 1,40	0,025	0,020	≤ 0,30	≤ 0,30	≤ 0,08	0,020	0,30	0,010	0,040	0,02
26CrMo4-2	1.7219	0,22 to 0,29	≤ 0,35	0,50 to 0,80	0,025	0,020	0,90 to 1,20	--	0,15 to 0,30	--	0,30	--	--	--
11MnNi5-3	1.6212	≤ 0,14	≤ 0,50	0,70 to 1,50	0,025	0,015	--	0,30 <sup>d</sup> to 0,80	--	0,020	0,30	0,05	--	0,05
13MnNi6-3	1.6217	≤ 0,16	≤ 0,50	0,85 to 1,70	0,025	0,015	--	0,30 <sup>d</sup> to 0,85	--	0,020	0,30	0,05	--	0,05
12Ni14	1.5637	≤ 0,15	0,15 to 0,35	0,30 to 0,80	0,025	0,010	--	3,25 to 3,75	--	--	0,30	--	--	0,05
X12Ni5	1.5680	≤ 0,15	≤ 0,35	0,30 to 0,80	0,020	0,010	--	4,50 to 5,30	--	--	0,30	--	--	0,05
X10Ni9	1.5682	≤ 0,13	0,15 to 0,35	0,30 to 0,80	0,020	0,010	--	8,50 to 9,50	≤ 0,10	--	0,30	--	--	0,05

<sup>a</sup> Elements not included in this table shall not be intentionally added to the steel without the agreement of the purchaser, except for elements which may be added for finishing the cast. All appropriate measures shall be taken to prevent the addition of undesirable elements from scrap or other materials used in the steel making process.

<sup>b</sup> By agreement between purchaser and manufacturer, aluminium may be replaced by other elements having a similar effect.

<sup>c</sup> **Option 2:** In order to facilitate subsequent forming operation, an agreed maximum copper content lower than indicated and an agreed specified maximum tin content shall apply.

<sup>d</sup> The lower limit for the nickel content may be reduced to not less than 0,15 % for tubes with wall thickness not exceeding 10 mm

**Table 3 — Permissible deviations of the product analysis from specified limits on cast analysis given in table 2**

Element	Limiting value for the cast analysis in accordance with table 2 % by mass	Permissible deviation of the product analysis % by mass
C	≤ 0,29	± 0,02
Si	≤ 0,40	± 0,05
	> 0,40 to 0,50	+ 0,06
Mn	≤ 1,70	+ 0,10 - 0,05
P	≤ 0,025	+ 0,005
S	≤ 0,015	+ 0,003
	> 0,015 to ≤ 0,020	+ 0,005
Al	≥ 0,020	- 0,005
Cr	≤ 1,20	± 0,10
Cu	≤ 0,30	+ 0,05
Mo	≤ 0,30	± 0,05
Nb	≤ 0,05	+ 0,005
Ni	≤ 0,85	± 0,05
	0,85 ÷ 3,75	± 0,07
	3,75 ÷ 5,30	± 0,10
	5,30 ÷ 9,50	± 0,15
Ti	≤ 0,040	+ 0,01
V	≤ 0,05	+ 0,01

**Table 4 — Mechanical properties at room temperature for wall thickness up to and including 40 mm**

Steel grade		Tensile properties			
Name	Material number	Min. upper yield strength or proof strength $R_{eH}$ or $R_{p0,2}$ MPa *	Tensile strength $R_m$ MPa *	Min. elongation A % <sup>a</sup>	
				l	t
P215NL	1.0451	215 <sup>b</sup>	360 to 480	25	23
P255QL	1.0452	255	360 to 490	23	21
P265NL	1.0453	265 <sup>c</sup>	410 to 570	24	22
26CrMo4-2	1.7219	440	560 to 740	18	16
11MnNi5-3	1.6212	285	410 to 530	24	22
13MnNi6-3	1.6217	355	490 to 610	22	20
12Ni14	1.5637	345	440 to 620	22	20
X12Ni5	1.5680	390	510 to 710	21	19
X10Ni9	1.5682	510	690 to 840	20	18

<sup>a</sup> l = longitudinal t = transverse.  
<sup>b</sup> For a wall thickness ≤ 10 mm.  
<sup>c</sup> For a wall thickness ≤ 25 mm  
\* 1 MPA = 1N/mm<sup>2</sup>.

**Table 5 — Minimum impact energy**

Steel grade		Wall thickness <i>T</i> mm	Orientation of test pieces with respect to tube (axis)	Minimum average impact energy KV J at a temperature, in °C, of										
				-196	-120	-110	-100	-90	-60	-50	-40	-20	+20	
P215NL	1.0451	≤ 10	Longitudinal	-	-	-	-	-	-	-	-	40	45	55
P255QL	1.0452	≤ 25	Longitudinal	-	-	-	-	-	-	-	40	45	50	60
			Transverse	-	-	-	-	-	-	27	30	35	40	
		> 25 to ≤ 40	Longitudinal	-	-	-	-	-	-	-	-	40	45	55
			Transverse	-	-	-	-	-	-	-	-	27	30	35
P265NL	1.0453	≤ 25	Longitudinal	-	-	-	-	-	-	-	-	40	45	50
			Transverse	-	-	-	-	-	-	-	-	27	30	35
26CrMo4-2	1.7219	≤ 40	Longitudinal	-	-	-	-	-	-	40	40	45	50	60
			Transverse	-	-	-	-	-	-	27	27	30	35	40
11MnNi5-3	1.6212	≤ 40	Longitudinal	-	-	-	-	-	-	40	45	50	55	70
13MnNi6-3	1.6217		Transverse	-	-	-	-	-	-	27	30	35	40	45
12Ni14	1.5637	≤ 25	Longitudinal	-	-	-	40	45	50	55	55	60	65	
			Transverse	-	-	-	27	30	35	35	40	45	45	
		> 25 to ≤ 40	Longitudinal	-	-	-	-	40	45	50	50	55	65	
			Transverse	-	-	-	-	27	30	30	35	40	45	
X12Ni5	1.5680	≤ 25	Longitudinal	-	40	45	50	55	65	65	65	70	70	
			Transverse	-	27	30	30	35	45	45	45	50	50	
		> 25 to ≤ 40	Longitudinal	-		40	45	50	60	65	65	65	70	
			Transverse	-		27	30	30	40	45	45	45	50	
X10Ni9	1.5682	≤ 40	Longitudinal	40	50	50	60	60	70	70	70	70	70	
			Transverse	27	35	35	40	40	50	50	50	50	50	



## 8.4 Appearance and internal soundness

### 8.4.1 Appearance

**8.4.1.1** Tubes shall be free from external and internal surface defects that can be detected by visual examination.

**8.4.1.2** The internal and external surface finish of the tubes shall be typical of the manufacturing process and the heat treatment employed. Normally the finish and surface condition shall be such that any surface imperfections or marks requiring dressing can be identified.

**8.4.1.3** It shall be permissible to dress, only by grinding or machining, surface imperfections provided that after doing so, the wall thickness in the dressed area is not less than the specified minimum wall thickness. All dressed areas shall blend smoothly into the contour of the tube.

**8.4.1.4** Any surface imperfection, which is demonstrated to be deeper than 5 % of the wall thickness  $T$  or 3 mm, whichever is the smaller, shall be dressed.

This requirement does not apply to surface imperfection with a depth equal to or less than 0,3 mm.

**8.4.1.5** Surface imperfections which encroach on the specified minimum wall thickness shall be considered defects and tubes containing these shall be deemed not to comply with this Part of EN 10216.

### 8.4.2 Internal soundness

#### 8.4.2.1 Leak tightness

The tubes shall pass a hydrostatic test (see 11.8.1) or electromagnetic test (see 11.8.2) for leak tightness.

Unless option 4 is specified, the choice of the test method is at the discretion of the manufacturer.

**Option 4:** *The test method for verification of leak tightness in accordance with 11.8.1 or 11.8.2 is specified by the purchaser.*

#### 8.4.2.2 Non-destructive testing

Tubes of test category 2 shall be subjected to non-destructive testing for the detection of longitudinal imperfections, in accordance with 11.11.1.

**Option 5:** *Tubes of test category 2 shall be subjected to non-destructive testing for the detection of transverse imperfections in accordance with 11.11.2.*

**Option 6:** *Tubes of test category 2 shall be subjected to non-destructive testing for the detection of the laminar imperfections in accordance with 11.11.3.*

## 8.5 Straightness

The deviation from straightness of any tube length  $L$  shall not exceed  $0,0015 L$ . Deviations from straightness over any one metre length shall not exceed 3 mm.

## 8.6 Preparation of ends

Tubes shall be delivered with square cut ends. The ends shall be free from excessive burrs.

**Option 7:** *The tubes shall be delivered with bevelled ends (see figure 1). The bevel shall have an angle  $\alpha$  of  $30^\circ_{0^\circ}^{+5^\circ}$  with a root face  $C$  of  $(1,6 \pm 0,8)$  mm, except that for wall thicknesses  $T$  greater than 20 mm, an alternative bevel may be specified*

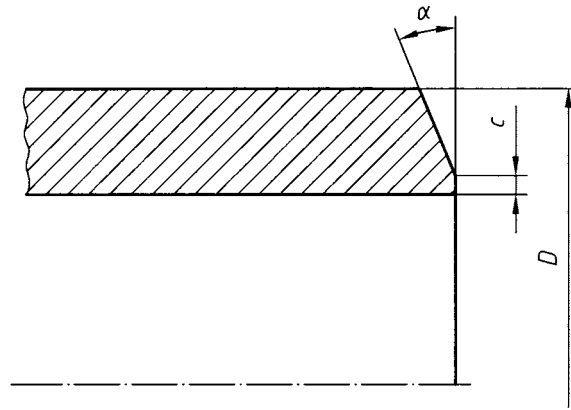

**Figure 1 — Tube end bevel**

## **8.7 Dimensions, masses and tolerances**

### **8.7.1 Diameter and wall thickness**

Tubes shall be delivered by outside diameter  $D$  and wall thickness  $T$ .

Preferred outside diameters  $D$  and wall thicknesses  $T$  have been selected from ENV 10220 and are given in table 6.

NOTE Dimensions which are different from those in table 6 may be agreed.

### **8.7.2 Mass**

For the mass per unit length the provisions of ENV 10220 apply.



**Table 6** (concluded)

Dimensions in mm

Outside diameter <i>D</i> Series <i>a</i>			Wall thickness <i>T</i> mm									
1	2	3	16	17,5	20	22,2	25	28	30	32	36	40
10,2												
	12											
	12,7											
13,5												
	16											
17,2												
	18											
	19											
	20											
21,3												
	22											
	25											
	25,4											
26,9												
	30											
	31,8											
	32											
33,7												
	35											
	38											
	40											
42,4												
	44,5											
48,3												
	51											
	54											
	57											
60,3												
	63,5											
	70											
	73											
76,1												
	82,5											
88,9												
	101,6											
	108											
114,3												
	127											
	133											
139,7												
	141,3											
	152,4											
	159											
168,3												
	177,8											
	193,7											
219,1												
	244,5											
273												
323,9												
355,6												
406,4												
457												
508												
	559											
610												
	660											
711												

<sup>a</sup> Series 1 = diameter for which all the accessories needed for the construction of piping system are standardized

Series 2 = diameter for which not all the accessories are standardized

Series 3 = diameter for special application for which very few standardized accessories exist

### 8.7.3 Lengths

Unless option 8 is specified, the tubes shall be delivered in random length. The delivery range shall be agreed at the time of ordering.

**Option 8:** The tubes shall be delivered in exact lengths, with the length being specified at the time of ordering. For tolerances, see 8.7.4.2.

### 8.7.4 Tolerances

#### 8.7.4.1 Tolerances on diameter and thickness

The diameter and the wall thickness of the tubes shall be within the relevant tolerance limits given in tables 7 or 8.

Out of roundness is included in the tolerances on diameter and eccentricity is included in the tolerances on wall thickness.

**Table 7 — Tolerances on outside diameter and wall thickness**

Outside diameter $D$ mm	Tolerances on $D$	Tolerances on $T$ for a $T/D$ ratio			
		$\leq 0,025$	$> 0,025$ $\leq 0,050$	$> 0,050$ $\leq 0,10$	$> 0,10$
$D \leq 219,1$	$\pm 1\%$ or $\pm 0.5$ mm, whichever is greater	$\pm 12,5\%$ or $\pm 0.4$ mm, whichever is greater			
$D > 219,1$		$\pm 20\%$	$\pm 15\%$	$\pm 12,5\%$	$\pm 10\%$ <sup>a</sup>

<sup>a</sup> For outside diameters  $\geq 355,6$  mm, it is permitted to exceed the upper wall thickness locally by a further 5% of the wall thickness.

**Table 8 — Tolerances on outside diameter and wall thickness for tube ordered cold finished**

Tolerance on $D$	Tolerance on $T$
$\pm 0,5\%$ or $\pm 0,3$ mm whichever is greater	$\pm 10\%$ or $\pm 0,2$ mm whichever is greater

#### 8.7.4.2 Tolerances on exact lengths

The tolerances for exact lengths shall be as given in table 9.

**Table 9 — Tolerances on exact lengths**

Length $L$	Dimensions in mm	
	Tolerance on exact length	
Up to 6000	+10	0
Above 6000 up to 12 000	+15	0
Above 12 000	+ By agreement	0

## 9 Inspection

### 9.1 Types of inspection

Conformity to with the requirements of the order, for tubes in accordance with this Part of EN 10216, shall be checked by specific inspection.

When an inspection document 3.1.B is specified for material of quality TR2, the material manufacturer shall state in the confirmation of the order whether he is operating according to a quality assurance system certified by a competent body established within the Community, and having undergone a specific assessment for materials.

NOTE See Directive 97/23/EC, Annex I, Section 4.3, third paragraph.

### 9.2 Inspection documents

#### 9.2.1 Types of inspection documents

Unless option 13 is specified, an inspection certificate 3.1.B, in accordance with EN 10204, shall be issued.

**Option 13:** One of the inspection documents 3.1.A, 3.1.C or 3.2 in accordance with EN 10204 shall be issued.

If an inspection document 3.1.A, 3.1.C or 3.2 is specified, the purchaser shall notify the manufacturer of the name and address of the organisation or person who is to carry out the inspection and produce the inspection document. In the case of inspection report 3.2 it shall be agreed which party shall issue the certificate.

NOTE: Document 3.1.A is not acceptable for compliance with Directive 97/23/EC.

#### 9.2.2 Content of inspection documents

The content of the inspection document shall be in accordance with prEN 10168.

In all type of inspection documents a statement on the conformity of the products delivered with the requirements of this specification and the order shall be included.

The inspection certificate or inspection report shall contain the following codes and information :

- A commercial transactions and parties involved;
- B description of products to which the inspection document applies;
- C02-C03 direction of the test pieces and testing temperature;
- C10-C13 tensile test;
- C40-C43 impact test if applicable;
- C60-C69 other tests;
- C71-C92 chemical composition on cast analysis (product analysis if applicable);
- D01 marking and identification, surface appearance, shape and dimensional properties;
- D02-D99 leak tightness test, NDT, material identification, if applicable;
- Z validation.

In addition to the inspection document 3.1.B, the manufacturer shall state the references to the certificate (see 9.1) of the appropriate 'quality assurance system', if applicable.

### 9.3 Summary of inspection and testing

Non-alloy steel tubes shall be inspected and tested in accordance with test category 1 or test category 2 as specified at the time of ordering (see 6.1).

Alloyed steel tubes shall be inspected and tested in accordance with test category 2 (see table 10).

Inspection and testing to be carried out are summarized in table 10.

**Table 10 — Summary of inspection and testing**

Type of inspection and test		Frequency of testing	Refer to	Test category	
				1	2
Mandatory tests	Cast analysis	Once per cast	8.2.1 - 11.1	X	X
	Tensile test at ambient temperature	Once per sample tube	8.3.1 - 11.2.1	X	X
	Flattening test for $D < 600$ mm and a $T/D$ ratio $\leq 0,15$ but $T \leq 40$ mm or <sup>a</sup> Ring tensile test for $D > 150$ mm and $T \leq 40$ mm		8.3 - 11.3 -11.4	X	X
	Drift expanding test for $D \leq 150$ mm and $T \leq 10$ mm or <sup>a</sup> Ring expanding test for $D \leq 114.3$ mm and $T \leq 12,5$ mm		8.3 - 11.5 - 11.6	X	X
	Impact test at low temperature		8.3.2 - 11.7	X	X
	Leak tightness test		Each tube	8.4.2. - 11.8	X
	Dimensional inspection	8.7 - 11.9		X	X
	Visual examination	11.10		X	X
	NDT for detection of longitudinal imperfections	Each tube	8.4.2.2 - 11.11.1	--	X
	Material identification of alloy steel		11.12	X	X
	Optional tests	Product analysis (Option 3)	Once per cast	8.2.2 - 11.1	X
Wall thickness measurement away from tube ends (Option 11)		See 11.9.		X	X
NDT for the detection of transverse imperfections (Option 5)		Each tube	8.4.2.2 - 11.11.2	--	X
NDT for the detection o laminar imperfections (Option 6)			8.4.2.2 - 11.11.3	--	X
<sup>a</sup> The choice of flattening test or ring tensile test and of drift expanding test or ring expanding test is up to the manufacturer.					

## 10 Sampling

### 10.1 Frequency of tests

#### 10.1.1 Test unit

A test unit shall comprise tubes of the same specified diameter and wall thickness, the same steel grade, the same cast, the same manufacturing process, subjected to the same finishing treatment in a continuous furnace or heat treated in the same furnace charge in a batch-type furnace.

The number of tubes per test unit shall conform to table 11:

**Table 11 — Number of tubes per test unit**

Outside diameter $D$ mm	Maximum number of tubes per test unit
Up to 114,3	200
Above 114,3 up to 323,9	100
Above 323,9	50

### 10.1.2 Number of sample tubes per test unit

The following number of sample tubes shall be selected from each test unit.

test category 1 one sample tube.

test category 2 two sample tubes; when the total number of tubes is less than 20, only one sample tube.

## 10.2 Preparation of samples and test pieces

### 10.2.1 Selection and preparation of samples for product analysis

Samples for product analysis shall be taken from the test pieces or samples for mechanical testing or from the whole wall thickness of the tube at the same location as the mechanical test samples in accordance with ISO 14284.

### 10.2.2 Location, orientation and preparation of samples and test pieces for mechanical tests

#### 10.2.2.1 General

Samples and test pieces shall be taken at the tube ends and in accordance with the requirements of EN ISO 377.

#### 10.2.2.2 Test pieces for tensile tests

The test pieces for the tensile tests shall be prepared in accordance with EN 10002-1.

At the manufacturer's discretion:

for tubes with an outside diameter  $\leq 219,1$  mm the test piece shall be either a full tube section or a strip section and shall be taken in a direction longitudinal to the axis of the tube;

for tubes with an outside diameter  $> 219,1$  mm the test piece shall either a machined test piece with circular cross section from an unflattened sample or a strip section and be taken in a direction either longitudinal or transverse to the axis of the tube.

#### 10.2.2.3 Test pieces for the flattening test, ring tensile test, drift expanding test and ring expanding test

The test pieces for the flattening test, ring tensile test, drift expanding test and the ring expanding test shall consist of a full tube section in accordance with EN 10233, EN 10237, EN 10234 or EN 10236.

#### 10.2.2.4 Test pieces for impact test

Three standard Charpy V-notch test pieces shall be prepared in accordance with EN 10045-1. If the wall thickness is such that standard test pieces cannot be produced without flattening of the section, then test pieces of width less than 10 mm, but not less than 5 mm shall be prepared; the largest obtainable width shall be used.

Where test pieces at least 5 mm width cannot be obtained, the tubes shall not be subject to impact testing.



The test pieces shall be taken transverse to the tube axis unless  $D_{\min}$ , as calculated by the following equation, is greater than the specified outside diameter, in which case longitudinal test pieces shall be used:

$$D_{\min} = (T-5) + [ 756,25 / (T-5) ] \quad (1)$$

Test pieces shall be prepared such that the axis of the notch is perpendicular to the surface of the tube see figure 2.

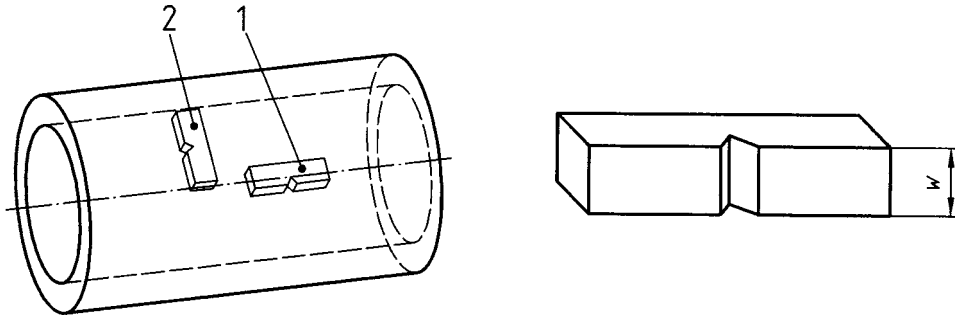

Key:

- 1 Longitudinal test piece
- 2 Transverse test piece

**Figure 2 — Impact test piece orientation**

## 11 Test methods

### 11.1 Chemical analysis

The elements to be determined and reported shall be those specified in table 2. The choice of a suitable physical or chemical analytical method for the analysis shall be at the discretion of the manufacturer. In cases of dispute, the method used shall be agreed between the manufacturer and the purchaser, taking into account CR10261.

### 11.2 Tensile test

The test shall be carried out at room temperature in accordance with EN 10002-1, and the following determined:

- the tensile strength ( $R_m$ );
- the upper yield strength ( $R_{eH}$ ) or if a yield phenomenon is not present the 0,2 % proof strength ( $R_{p0,2}$ );
- the percentage elongation after fracture with a reference to a gauge length ( $L_0$ ) of  $5,65 \cdot \sqrt{S_0}$ ; if a non-proportional test piece is used, the percentage elongation value shall be converted to the value for a gauge length  $L_0 = 5,65 \cdot \sqrt{S_0}$  using the conversion tables in EN ISO 2566-1.

### 11.3 Flattening test

The test shall be carried out in accordance with EN 10233.

The tube section shall be flattened in a press until the distance between platens  $H$  reaches the value given by the following equation:

$$H = \frac{(1 + C)}{C + (T/D)} x T \quad (2)$$

where :

- $H$  is the distance between platens, in mm, to be measured under load;
- $D$  is the specified outside diameter, in mm;
- $T$  is the specified wall thickness, in mm;
- $C$  is the constant factor of deformation the value of which is given in table 12.

**Table 12 — Flattening test: Constant factor of deformation  $C$**

Steel grade		$C$
Name	Material number	
P 215NL	1.0451	0,09
P 255QL	1.0452	0,09
P 265NL	1.0453	0,07
26CrMo4-2	1.7219	0,06
11MnNi5-3	1.6212	0,07
13MnNi6-3	1.6217	0,07
12Ni14	1.5637	0,08
X12Ni5	1.5680	0,06
X10Ni9	1.5682	0,06

After testing, the test piece shall be free from cracks or breaks. However, slight incipient cracks at its edges shall not be regarded as justification for rejection.

#### **11.4 Ring tensile test**

The test shall be carried out in accordance with EN 10237.

The tube section shall be subjected to strain in the circumferential direction until fracture occurs.

After fracture the test pieces shall not show any visible cracks without the use of magnifying aids (excluding the fracture point).

#### **11.5 Drift expanding test**

The test shall be carried out in accordance with EN 10234.

The tube section shall be expanded with a 60° conical tool until the percentage increase in outside diameter shown in table 13 is reached.

**Table 13 — Drift expanding test requirements**

Steel grade	Percentage increase in outside diameter for $d/D^a$		
	$\leq 0,6$	$> 0,6 \leq 0,8$	$> 0,8$
All steel grades	8	10	15
$a \quad d = D - 2T.$			

After testing, the test piece shall be free from cracks or breaks. However, slight incipient cracks at its edges shall not be regarded as justification for rejection.

### 11.6 Ring expanding test

The test shall be carried out in accordance with EN 10236.

The tube section shall be expanded with a conical tool until it breaks. The surface outside the fracture zone shall be free from cracks or breaks. However, slight incipient cracks at its edges shall not be regarded as justification for rejection.

### 11.7 Impact test

**11.7.1** The test shall be carried out in accordance with EN 10045-1, at the lowest temperature specified in table 5 for the steel grade concerned.

**11.7.2** The mean value of the three test pieces shall meet the requirements given in table 5. One individual value may be below the specified value, provided that it is not less than 70 % of that value.

**11.7.3** If the width of the test piece is less than 10 mm, the measured impact energy ( $KV_p$ ) shall be converted to the calculated impact energy ( $KV_c$ ) using the following equation:

$$KV_c = \frac{10 \times KV_p}{W} \quad (3)$$

where:

- $KV_c$  is the calculated impact energy, in J;
- $KV_p$  is the measured impact energy, in J;
- $W$  is the width of the test piece, in mm.

The calculated impact energy shall conform to with the requirements given in 11.7.2.

**11.7.4** If the requirements of 11.7.2 are not met, then an additional set of three test pieces may be taken at the discretion of the manufacturer from the same sample and tested. To consider the test unit as conforming, after testing the second set, the following conditions shall be satisfied simultaneously:

the average value of the six tests shall be equal to or greater than the specified minimum average value;

not more than two of the six individual values may be lower than the specified minimum average value;

not more than one of the six individual values may be lower than 70 % of the specified minimum average value.

**11.7.5** The dimensions in millimetres of the test pieces, the measured impact energy values and the resulting average value shall be reported.

## 11.8 Leak tightness test

### 11.8.1 Hydrostatic test

The hydrostatic test shall be carried out at a test pressure of 70 bar<sup>2)</sup> or at a test pressure  $P$  calculated using the following equation, whichever is lower:

$$P = 20 \frac{S \times T}{D} \quad (4)$$

where :

- $P$  is the test pressure, in bar;
- $D$  is the specified outside diameter, in mm;
- $T$  is the specified wall thickness, in mm;
- $S$  is the stress, in MPa, corresponding to 70 % of the specified minimum yield strength (see table 4) for the steel grade concerned.

The test pressure shall be held for not less than 5 s for tubes with an outside diameter less than or equal to 457 mm and for not less than 10 s for tubes with an outside diameter greater than 457 mm.

The tube shall withstand the test without showing leakage or visible deformation.

NOTE This hydrostatic leak tightness test is not a strength test.

**Option 10:** A test pressure different from that specified in 11.8.1 and corresponding to stresses below 90% of the specified minimum yield strength (see table 4) for the steel grade concerned is specified.

### 11.8.2 Electromagnetic test

The test shall be carried out in accordance with EN 10246-1.

## 11.9 Dimensional inspection

Specified dimensions, including straightness, shall be verified.

The outside diameter shall be measured at the tube ends. For tubes with an outside diameter  $\geq 406,4$  mm, the diameter may be measured using a circumference tape.

Unless option 11 is specified the wall thickness shall be measured at both tube ends.

**Option 11:** The wall thickness shall be measured away from the tube ends in accordance with an agreed procedure.

### 11.10 Visual examination

Tubes shall be visually examined to ensure conformity to the requirements of 8.4.1.

---

2) 1 bar = 100 kPa.

## 11.11 Non-destructive testing

**11.11.1** Tubes of test category 2 shall be subjected to Non-destructive testing for the detection of longitudinal imperfections, in accordance with EN 10246-7, to acceptance level U2, subcategory C, or EN 10246-5 acceptance level F2.

Unless option 12 is specified, the selection of the method is at the discretion of the manufacture.

**Option 12:** *The test method is specified by the purchaser.*

Regions at the tube ends not automatically tested shall either be subjected to manual/semi-automatic ultrasonic testing in accordance with EN 10246-7 to acceptance level U 2, subcategory C, or be cropped off.

**11.11.2** If option 5 (see 8.4.2.2) is specified, the tubes shall be submitted to ultrasonic testing for the detection of transverse imperfections in accordance with EN 10246-6 to acceptance level U2, subcategory C.

**11.11.3** If option 6 (see 8.4.2.2) is specified the tubes shall be submitted to ultrasonic testing for the detection of the laminar imperfections in accordance with EN 10246-14 to acceptance level U2.

## 11.12 Material identification

Each tube made from alloy steel (see 5.1) shall be tested by an appropriate method to ensure that the correct grade is being supplied.

## 11.13 Retests, sorting and reprocessing

For retest, sorting and reprocessing the requirements of EN 10021 shall apply.

## 12 Marking

### 12.1 Marking to be applied

The marking shall be indelibly marked on each tube at least at one end. For tubes with outside diameter  $\leq 51$  mm, the marking on tubes may be replaced by the marking on a label attached to the bundle or box.

The marking shall include the following information:

- the manufacturer's name or trade mark ;
- the number of this European standard and the steel name (see 5.2);
- the test category in case of non-alloy steel grades;
- the cast number or a code number;
- the mark of the inspection representative;
- an identification number (e.g. order or item number) which permits the correlation of the product or delivery unit to the related documents.

Example of marking:

X - EN 10216-4 - P265NL - TC1 - Y - Z<sub>1</sub> - Z<sub>2</sub>

where:

- X is the manufacturer's mark;
- TC1 is the designation of the test category 1;

- Y is the cast number or a code number;
- Z<sub>1</sub> is the mark of the inspection representative;
- Z<sub>2</sub> is the identification number.

## 12.2 Additional marking

*Option 13: Additional marking, as agreed upon at the time of ordering, shall be applied.*

## 13 Protection

The tubes shall be delivered without a temporary protective coating.

*Option 14: A temporary protective coating or durable coating and/or lining shall be applied.*

## Annex ZA (informative)

### Relationship between this European Standard and the Essential requirements of EU Directive 97/23/EC

This European Standard has been prepared under a mandate given to CEN by the European Commission and the European Free Trade Association to provide a means of conforming to Essential Requirements of the New Approach Directive 97/23/EC.

Once this standard is cited in the Official Journal of the European Union under that Directive and has been implemented as a national standard in at least one member state, compliance with the clauses of this standard given in table ZA.1 confers, within the limits of the scope of this standard, a presumption of conformity with the corresponding Essential requirements of that Directive and associated EFTA regulations.

**Table ZA.1 — Correspondence between this European Standard and the essential requirements of EU Directive 97/23/EC**

Clauses/subclauses of this EN	Essential requirements of Directive 97/23/EC	Qualifying remarks/Notes
8.3	Annex I, 4.1 a	Appropriate material properties
7.3 and 8.4	Annex I, 4.1d	Suitable for the processing procedures
9 and 10	Annex I, 4.3	Documentation

**WARNING:** Other requirements and other EC Directives may be applicable to the product(s) coming under the scope of this standard.

## Bibliography

EN 473, *Non destructive testing - Qualification and certification of NDT personnel - General principles*