

Steel threaded pipe fittings
English version of DIN EN 10241

DIN
EN 10241

ICS 23.040.40

Stahlittings mit Gewinde

Supersedes DIN 2980, DIN 2982, DIN 2983, DIN 2986, DIN 2987-1, DIN 2987-2, DIN 2988, DIN 2990, DIN 2991, DIN 2993, September 1977 editions, and DIN 2981, August 1982 edition.

European Standard EN 10241 : 2000 has the status of a DIN Standard.

A comma is used as the decimal marker.

National foreword

This standard has been prepared by ECISS/TC 29.

The responsible German body involved in its preparation was the *Normenausschuss Rohrleitungen und Dampfkesselanlagen* (Pipelines and Pressure Vessels Standards Committee), Technical Committee *Fittings*. The DIN Standards corresponding to the International Standards referred to in clause 2 of the EN are as follows:

ISO 7-1	DIN 2999-1
ISO 228-1	DIN ISO 228-1
ISO 6708	DIN EN ISO 6708

Amendments

DIN 2980, DIN 2982, DIN 2983, DIN 2986, DIN 2987-1, DIN 2987-2, DIN 2988, DIN 2990, DIN 2991, DIN 2993, September 1977 editions, and DIN 2981, August 1982 edition, have been superseded by the specifications of EN 10241.

Previous edition

DIN 2980: 1942-03, 1962-06, 1977-09; DIN 2981: 1942-03, 1962-06, 1977-09, 1982-08;
DIN 2982: 1942-03, 1962-06, 1977-09; DIN 2983: 1942-03, 1962-06, 1977-09;
DIN 2986: 1942x-03, 1959-08, 1977-09; DIN 2987: 1942x-03; DIN 2987-1: 1962-06, 1977-09;
DIN 2987-2: 1962-06, 1977-09; DIN 2988: 1942x-03, 1959x-08, 1977-09;
DIN 2990: 1942x-03, 1962-06, 1977-09; DIN 2991: 1942-03, 1962-06, 1963-04, 1977-09;
DIN 2993: 1942-03, 1962-08, 1977-09.

National Annex NA

Standards referred to

(and not included in **Normative references**)

DIN 2999-1	Pipe threads for tubes and fittings – Parallel internal threads and taper external threads – Thread dimensions
DIN EN ISO 6708	Pipework components – Definition and selection of DN (nominal size) (ISO 6708 : 1995)

EN comprises 31 pages.

ICS 23.040.40

English version

Steel threaded pipe fittings

Raccords filetés en acier

Stahl fittings mit Gewinde

This European Standard was approved by CEN on 2000-29-03.

CEN members are bound to comply with the CEN/CENELEC Internal Regulations which stipulate the conditions for giving this European Standard the status of a national standard without any alteration.

Up-to-date lists and bibliographical references concerning such national standards may be obtained on application to the Central Secretariat or to any CEN member.

The European Standards exist in three official versions (English, French, German). A version in any other language made by translation under the responsibility of a CEN member into its own language and notified to the Central Secretariat has the same status as the official versions.

CEN members are the national standards bodies of Austria, Belgium, the Czech Republic, Denmark, Finland, France, Germany, Greece, Iceland, Ireland, Italy, Luxembourg, the Netherlands, Norway, Portugal, Spain, Sweden, Switzerland, and the United Kingdom.

CEN

European Committee for Standardization
Comité Européen de Normalisation
Europäisches Komitee für Normung

Central Secretariat: rue de Stassart 36, B-1050 Brussels

Contents

Foreword.....	3
1 Scope	4
2 Normative references	4
3 Terms and definitions.....	4
4 Designation.....	5
5 Information to be supplied by the purchaser.....	5
5.1 Mandatory information	5
5.2 Options.....	5
6 Technical requirements.....	6
6.1 Fitting manufacture	6
6.2 Surface condition.....	6
6.3 Material.....	6
6.3.1 Chemical composition.....	6
6.3.2 Mechanical properties	6
6.4 Threads	7
7 Dimensions and tolerances	7
7.1 Dimensions.....	7
7.2 Tolerances	7
7.2.1 Tolerances on length of fitting	7
7.2.2 Tolerances on diameters.....	8
7.2.3 Tolerance on threads.....	8
8 Protection	8
8.1 General.....	8
8.2 Zinc protective coating.....	8
8.2.1 Hot dip zinc galvanizing	8
8.2.2 Electro zinc plating	8
8.2.3 Zinc flake.....	8
9 Inspection and testing.....	8
9.1 Leaktightness test	8
9.1.1 Hydrostatic test.....	8
9.1.2 Air test.....	9
9.2 Inspection of threads.....	9
9.2.1 Inspection method.....	9
9.2.2 Thread electro zinc plating	9
10 Marking	9
11 Packaging	9
12 Inspection documents.....	9
Annex A (informative) Thread designation and nominal size	31

Foreword

This European Standard has been prepared by Technical Committee ECISS/TC 29 "Steel tubes and fittings for steel tubes", the secretariat of which is held by UNI.

This European Standard shall be given the status of a national standard, either by publication of an identical text or by endorsement, at the latest by October 2000, and conflicting national standards shall be withdrawn at the latest by October 2000.

According to the CEN/CENELEC Internal Regulations, the national standards organizations of the following countries are bound to implement this European Standard: Austria, Belgium, Czech Republic, Denmark, Finland, France, Germany, Greece, Iceland, Ireland, Italy, Luxembourg, Netherlands, Norway, Portugal, Spain, Sweden, Switzerland and the United Kingdom.

1 Scope

This European standard specifies requirements for threaded fittings of nominal sizes from DN 6 to DN 150 inclusive, made out of welded or seamless steel tubes, forging and rolled bars. It is applicable to those threaded steel pipe fittings that are used in the transportation and distribution of liquid or gas.

2 Normative references

This European standard incorporates by dated or undated reference, provisions from other publications. These normative references are cited at the appropriate places in the text and the publications are listed hereafter. For dated references, subsequent amendments to or revisions of any of these publications apply to this European standard only when incorporate in it by amendments or revision. For undated references, the latest edition of the publication referred to applies (including amendments).

EN 10204, *Metallic products - Types of inspection documents.*

EN ISO 6708, *Pipework components - Definition and selection of DN (nominal size) (ISO 6708:1995)*

ISO 7-1¹⁾, *Pipe threads where pressure-tight joints are made on the threads - Part 1: Dimensions, tolerances and designation.*

ISO 7-2¹⁾, *Pipe threads where pressure-tight joints are made on the threads - Part 2: Verification by means of limit gauges.*

ISO 228-1, *Pipe threads where pressure-tight joints are not made on the threads - Part 1: Dimensions, tolerances and designation.*

ISO 228-2, *Pipe threads where pressure-tight joints are not made on the threads - Part 2: Verification by means of limit gauges.*

3 Terms and definitions

For the purposes of this Standard, the following terms and definitions apply :

3.1

nominal size (DN)

DN : as defined in EN ISO 6708

NOTE The comparison between the thread size designation and the nominal size (DN) is given in table A.1 for information only.

3.2

seamless fitting

Fitting manufactured from seamless tube, forging or rolled bar

3.3

fabricated fitting

Fitting manufactured either from a welded tube or where the welding forms part of the fabrication of the fitting

3.4

tubular

Fitting manufactured from medium or heavy pipe as defined in table 6. These fittings are defined in tables 21 to 24

¹⁾ European standards are under development (series EN 10226). When published, they may be agreed at the time of enquiry and/or order.

4 Designation

The fitting in accordance with this European Standard shall be designated by the following in the sequence shown :

- 1) type of fitting (see tables 7 to 24) ;
- 2) reference to this European Standard (EN 10241) ;
- 3) either nominal size (DN), or thread size.

Fittings which have the same nominal sizes (DN) are designated only with that DN (see example 1).

EXAMPLE 1 :

For an equal female elbow with DN 50 run, the designation will be :

Elbow - EN 10241 - DN 50

Fitting which has differing nominal sizes shall be shown as in the sequence 1-2 where 1 refers to the run and 2 refers to the branch or the reduction (see examples 2 and 3).

EXAMPLE 2 :

For a reducing tee with DN 50 run and DN 25 branch, the designation will be :

Reducing tee - EN 10241 - DN 50 X DN 25

EXAMPLE 3 :

For a bush with DN 40 and a reduction DN 25, the designation will be :

Bush - EN 10241 - DN 40 X DN 25

5 Information to be supplied by the purchaser

5.1 Mandatory information

The following information shall be supplied by the purchaser, at the time of enquiry and/or order :

- 1) the quantity to be delivered ;
- 2) the designation (see clause 4).

5.2 Options

A number of options are specified in this European Standard and they are listed below.

In the event that the purchaser does not indicate a wish to implement any of these options at the time of enquiry and/or order, the fittings shall be supplied in accordance with the basic specification.

- 1) taper internal thread type Rc conforming to ISO 7-1 ;
- 2) parallel external thread type GA or GB conforming to ISO 228-1 ;
- 3) parallel internal thread type G conforming to ISO 228-1.
- 4) zinc protective coating (see 8.2) ;
- 5) leaktightness test (see 9.1) ;

- 6) special packaging (see clause 11) ;
- 7) inspection document 2.1 (see clause 12) ;

6 Technical requirements

6.1 Fitting manufacture

Dimensions and tolerances of differing types of fittings shall be as given in tables 5 to 24.

6.2 Surface condition

The fitting shall have a smooth surface consistent with the manufacturing process and be free from burrs ; surface marks may be ground. Unless otherwise specified in the tables 11 and 12, the female thread entrance shall be chamfered.

Repairs by welding, other than the weld seam, are forbidden.

6.3 Material

6.3.1 Chemical composition

The fitting shall be manufactured from steel having the chemical composition indicated in tables 1 and 2.

Table 1 - Chemical composition of seamless steel fittings

C max. %	S max. %	P max. %
0,25	0,35	0,09

Table 2 - Chemical composition of fabricated fittings and tubulars

C max. %	Mn max. %	P max. %	S max. %
0,25	1,40	0,045	0,045

6.3.2 Mechanical properties

The fitting shall be manufactured from base material having the mechanical properties indicated in tables 3 and 4
These properties shall not be subject to verification on the fitting.

Table 3 - Mechanical properties of seamless steel fittings

Tensile strength min. N/mm ²	Elongation min. %
320	20

Table 4 - Mechanical properties of fabricated fittings and tubulars

Tensile strength min. N/mm ²	Yields strength min. N/mm ²	Elongation min. %
320	195	20

6.4 Threads

Internal threads shall be parallel and external threads shall be taper conforming to ISO 7-1, except for certain tubulars in tables 21, 23 and 24 or when the purchaser specifies other types of thread (see 5.2, option 1 or 2 or 3), in this case the type of thread shall be identified.

7 Dimensions and tolerances

7.1 Dimensions

Fittings shall have the appropriate dimensions given in tables 6 to 24.

7.2 Tolerances

When tolerances are not specified in tables 5 to 24, dimensions are nominal and subjected to manufacturing tolerances.

7.2.1 Tolerances on length of fitting

The tolerances on the overall length of the fitting, centre to face, centre to centre and back to face dimensions are given in table 5.

Table 5 - Tolerances

Dimensions in mm

Dimension	Up to and including 25	Over 25 to 40	Over 40 to 65	Over 65 to 75	Over 75 to 150	Over 150
Tolerance	+1,5 0	+ 3,0 0	+ 4,5 0	+ 6,0 0	+ 8,0 0	+10,0 0

7.2.2 Tolerances on diameters

Unless otherwise stated in tables, the tolerances on outside diameters are given in table 6.

7.2.3 Tolerance on threads

The axis of screw threads shall be accurate within $\pm 0,5^\circ$ of the specified angle for fittings described in tables 7 to 23 and $\pm 1,5^\circ$ for fittings described in table 24.

8 Protection

8.1 General

The fitting shall be supplied black and shall be protected by a protective coating, e.g : light oil.

8.2 Zinc protective coating

When a zinc protective coating is specified by the purchaser (see 5.2, option 4), one of the methods given in 8.2.1 to 8.2.3 shall be applied, at the discretion of the manufacturer.

8.2.1 Hot dip zinc galvanizing

Galvanizing of fittings shall be performed before the thread cutting operation and shall be by means of the hot dip method. The minimum average coating thickness shall be 55 μm on the outside of the fitting, with a local average of 45 μm on 100 mm^2 .

The hot dip zinc bath shall contain not less than 98,5 % pure zinc.

8.2.2 Electro zinc plating

Electro zinc plating shall be performed on the finished black fitting. The minimum coating thickness on the outside of the fitting shall be 8 μm .

8.2.3 Zinc flake

Zinc flake non-electrolically applied cured coating shall be performed on the finished black fitting. The coating thickness on the outside of the fitting shall be between 5 μm to 10 μm .

NOTE The zinc coating thickness can be checked with an electronic and/or magnetic appliance.

9 Inspection and testing

9.1 Leaktightness test

Each fitting, after being threaded, shall be capable of withstanding, without any signs of leakage, the hydrostatic or air test as specified in clauses 9.1.1 and 9.1.2. This test shall only be carried out when specified by the purchaser at the time of enquiry and/or order (see 5.2, option 5).

9.1.1 Hydrostatic test

Hydrostatic test, using water or light oil as a medium.

9.1.1.1 Tubulars

These shall be tested to a minimum internal pressure of 50 bar.

9.1.1.2 Fabricated fittings

These shall be tested to a minimum internal pressure of 75 bar.

9.1.1.3 Seamless fittings

These shall be tested to a minimum internal pressure of 150 bar.

9.1.2 Air test

Air test, with the fitting fully immersed in water or light oil as a medium.

Tubulars, fabricated fittings and seamless fittings shall be tested to a minimum internal air pressure of 7 bar.

9.2 Inspection of threads

9.2.1 Inspection method

Threads manufactured in accordance with ISO 7-1 shall be verified in accordance with ISO 7-2.

Threads manufactured in accordance with ISO 228-1 shall be verified in accordance with ISO 228-2.

9.2.2 Thread electro zinc plating

Where fittings have been electro zinc plating, this can result in the thread being covered in uneven particles of zinc ; these particles may be removed with a plug or a brush.

10 Marking

The manufacturer's brand or logo shall, depending on the size of fittings, either be applied on a label attached on the packaging or be marked indelibly on each fitting.

11 Packaging

Unless special packaging is specified by the purchaser at the time of enquiry and/or order (see 5.2, option 6), fittings shall be supplied, either singly or in sacks or bags.

12 Inspection documents

Fittings shall be delivered without an inspection document.

At the request of purchaser (see 5.2, option 7), the manufacturer shall provide a certificate of compliance, in accordance with EN 10204 type 2.1.

Table 6 - Threaded ends of fitting

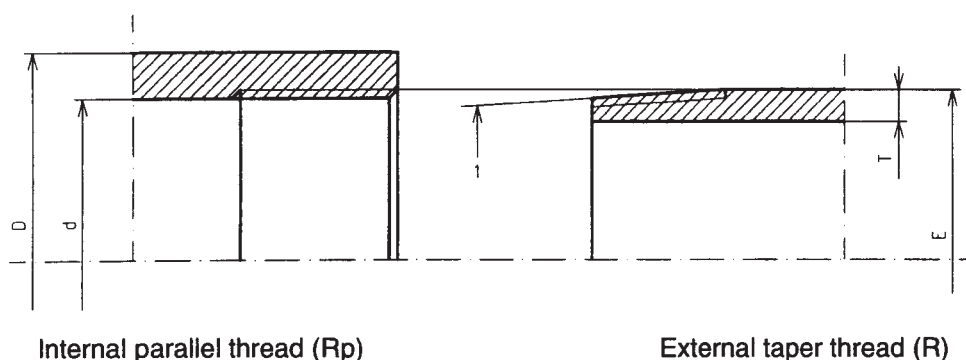

1 taper is 1 in 16 on diameter

Nominal size DN	Minimum outside diameter D 1) mm	Outside diameter of body behind external thread E 2) mm		Maximum inside diameter of body behind internal thread d 3) mm	Pipe thickness T 4) mm	
		Min.	Max.		Medium	Heavy
		6	15,0		9,8	10,6
8	18,5	13,2	14,0	11,4	2,3	2,9
10	22,0	16,7	17,5	15,0	2,3	2,9
15	27,0	21,0	21,8	18,6	2,6	3,2
20	32,5	26,5	27,3	24,1	2,6	3,2
25	39,5	33,3	34,2	30,3	3,2	4,0
32	49,0	42,0	42,9	39,0	3,2	4,0
40	56,0	47,9	48,8	44,8	3,2	4,0
50	68,0	59,7	60,8	56,5	3,6	4,5
65	84,0	75,3	76,6	72,2	3,6	4,5
80	98,0	88,0	89,5	84,9	4,0	5,0
100	124,0	113,1	115,0	110,1	4,5	5,4
125	151,0	138,5	140,8	135,5	5,0	5,4
150	178,0	163,9	166,5	160,9	5,0	5,4

1) The outside diameter D is a minimum for all fittings except equal sizes of socket and half socket. The minimum outside diameters of equal sizes of socket and half socket are given in tables 11 and 12.

2) E are minimum and maximum diameters for tubulars in tables 21 to 24 ; for other fittings, only the minimum is applicable.

3) The value d is not applicable to bushes described in table 15.

4) Wall thickness tolerances for tubulars shall be :

- no limit in plus ;
- 12,5 % minus.

Table 7 - Elbow, tee and cross, equal

		
Elbow, equal	Tee, equal	Cross, equal
Nominal size	Centre to face	
DN	A	
	mm	
6	16	
8	22	
10	24	
15	32	
20	35	
25	43	
32	51	
40	52	
50	64	
65	76	
80	89	
100	115	
125	140	
150	160	

Table 8 - Elbow, equal 45 degrees



Nominal size DN	Centre to face A mm
10	19
15	22
20	27
25	33
32	38
40	44
50	51
65	59
80	66
100	77
125	87
150	92

Table 9 - Elbow, male and female, equal

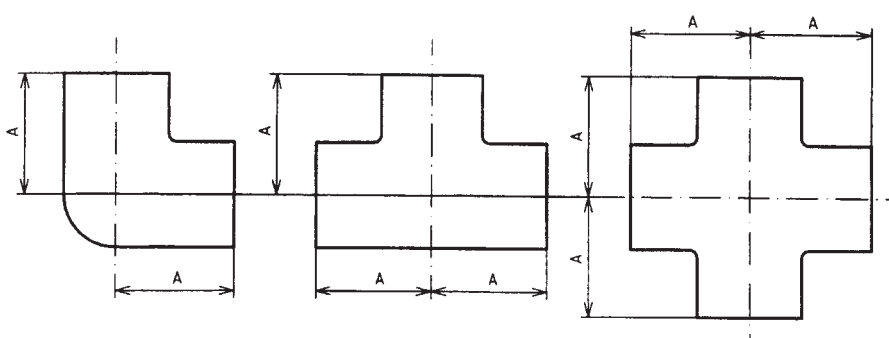
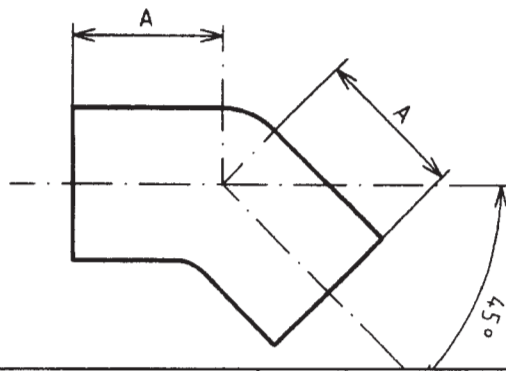
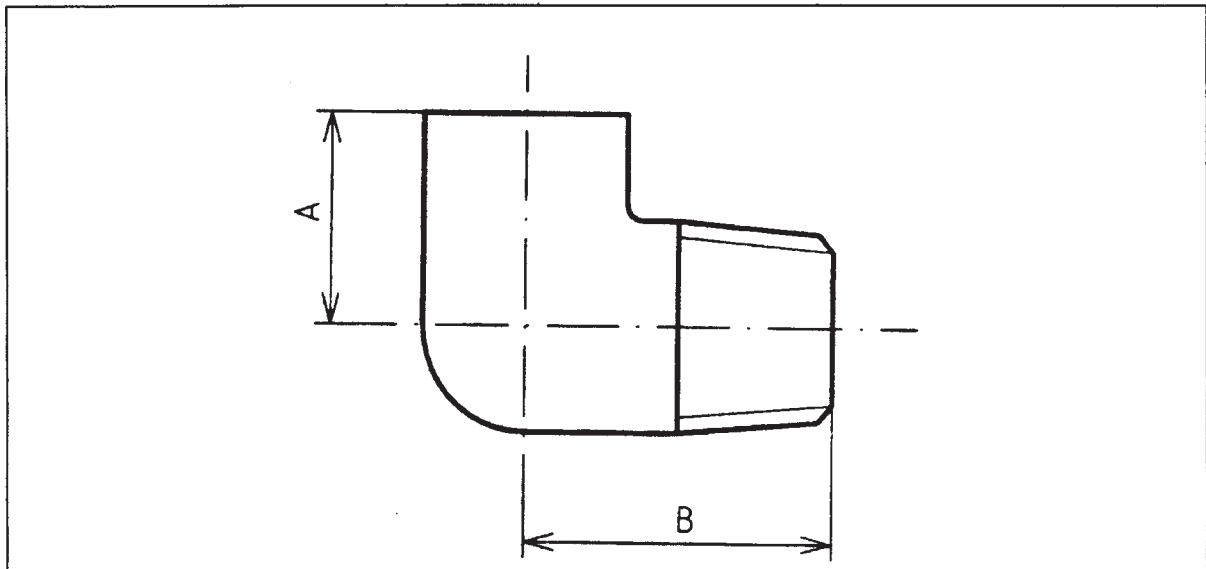

Nominal size DN	Centre to face <i>A</i> mm	Centre to face <i>B</i> mm	Bore of male end mm	
			Min.	Max.
8 10	19 21	27 29	6,5 8,5	8,0 10,5
15 20 25	25 30 37	35 40 46	11,5 18,0 24,0	13,0 21,0 26,0
32 40 50	43 49 59	54 57 70	30,0 37,0 48,0	32,0 39,0 51,0
65 80 100	68 81 100	83 94 115	62,0 75,0 97,0	66,0 79,0 104,0

Table 10 - Tee, reducing on the branch

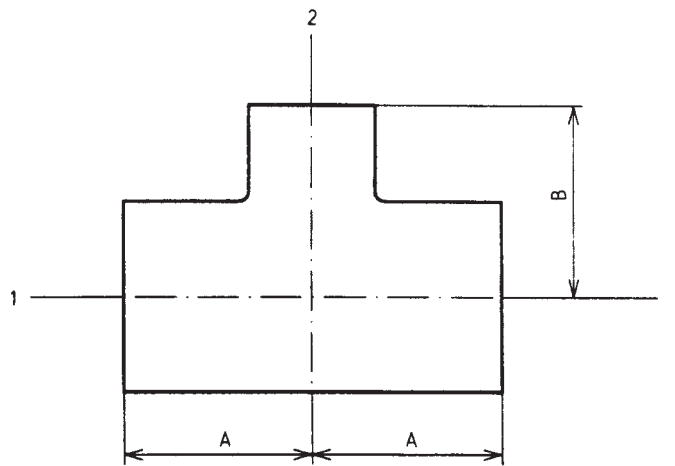

Nominal size DN 1 X DN 2	Centre to face A mm	Centre to face B mm	Nominal size DN 1 X DN 2	Centre to face A mm	Centre to face B mm
10 x 8 ¹⁾	22	24	50 x 15 ¹⁾	41	64
15 x 8	25	32	50 x 20 ¹⁾	44	64
15 x 10	27	32	50 x 25	48	64
20 x 8	27	35	50 x 32	52	64
20 x 10	29	35	50 x 40	56	64
20 x 15	32	35	65 x 25	54	76
25 x 8 ¹⁾	30	43	65 x 40	60	76
25 x 10 ¹⁾	32	43	65 x 50	67	76
25 x 15	35	43	80 x 25	60	89
25 x 20	38	43	80 x 32	64	89
32 x 15	38	51	80 x 40	67	89
32 x 20	41	51	80 x 50	73	89
32 x 25	44	51	80 x 65	79	89
40 x 15 ¹⁾	38	52	100 x 40	76	115
40 x 20	41	52	100 x 50	83	115
40 x 25	44	52	100 x 80	95	115
40 x 32	49	52	150 x 80	120	160
			150 x 100	135	160

1) Bushed tees may be supplied instead.

Table 11 - Socket and half socket, equal, type heavy

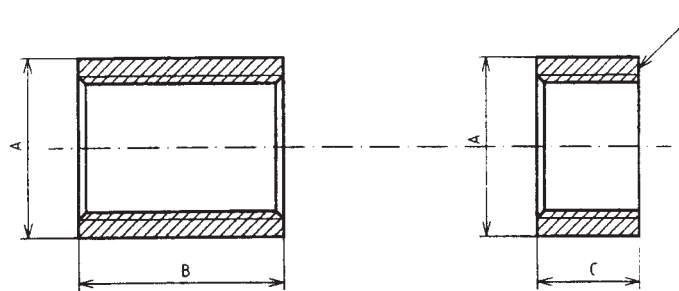

Socket

Half socket

1 faced at right angle to axis of thread. No internal chamfer.

Nominal size DN	Minimum outside diameter <i>A</i> mm	Overall length of socket <i>B</i> mm	Overall length of half socket <i>C</i> mm
6	15,0	19	8
8	18,5	27	11
10	22,0	28	12
15	27,0	37	16
20	32,5	39	19
25	39,5	46	21
32	49,0	51	25
40	56,0	51	25
50	68,0	60	28
65	84,0	69	30
80	98,0	75	35
100	124,0	87	40
125	151,0	96	44
150	177,0	96	44

Table 12 - Socket and half socket, equal, type medium

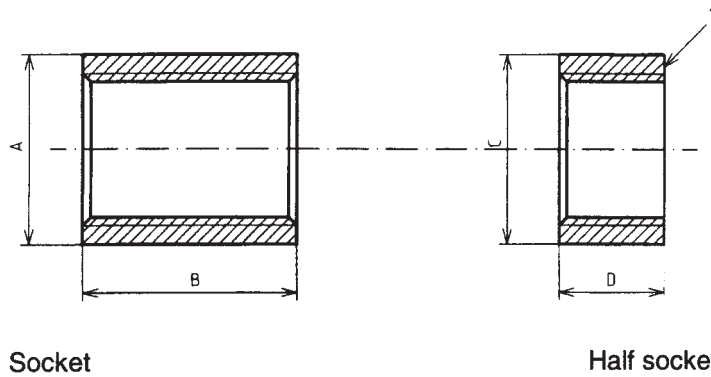

1 faced at right angle to axis of thread. No internal chamfer.

Nominal size	Minimum outside diameter of socket	Overall length of socket	Minimum outside diameter of half socket	Overall length of half socket
DN	<i>A</i>	<i>B</i>	<i>C</i>	<i>D</i>
	mm	mm	mm	mm
6	15,0	17	15,0	8
8	18,5	25	18,5	11
10	21,3	26	21,3	12
15	26,6	34	26,6	15
20	31,8	36	31,8	17
25	39,5	43	39,5	20
32	48,3	48	48,3	22
40	54,5	48	54,5	22
50	66,2	56	68,0	26
65	82,0	65	84,2	30
80	95,0	71	98,4	34
100	121,4	83	124,0	40
125	146,3	92	149,0	44
150	173,3	92	177,0	44

Table 13 - Reducing socket ¹⁾

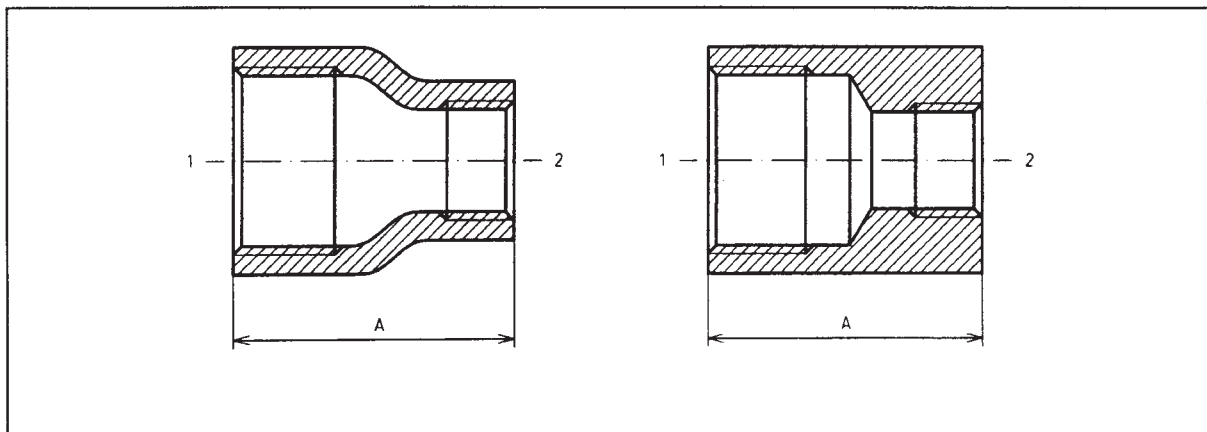

Nominal size DN 1 X DN 2	Overall length A mm	Nominal size DN 1 X DN 2	Overall length A mm
8 x 6	25	50 x 15	70
10 x 6	30	50 x 20	68
10 x 8	29	50 x 25	67
15 x 6	41	50 x 32	65
15 x 8	40	50 x 40	64
15 x 10	38	65 x 25	76
20 x 8	44	65 x 32	75
20 x 10	43	65 x 40	73
20 x 15	41	65 x 50	71
25 x 8	54	80 x 25	86
25 x 10	52	80 x 32	84
25 x 15	51	80 x 40	83
25 x 20	49	80 x 50	81
32 x 10	60	80 x 65	79
32 x 15	59	100 x 40	105
32 x 20	57	100 x 50	100
32 x 25	56	100 x 65	100
40 x 15	65	100 x 80	98
40 x 20	64	125 x 80	115
40 x 25	62	125 x 100	115
40 x 32	60	150 x 80	140
		150 x 100	140

1) The shape of reducing socket shall be at the option of the manufacturer.

Table 14 - Hexagonal nipple, equal

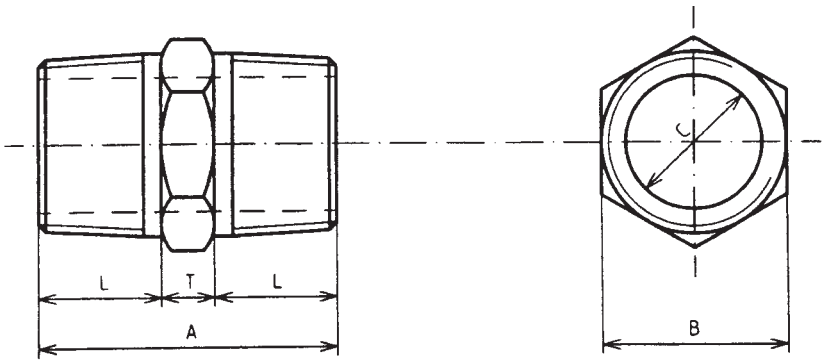

Nominal size DN	Minimum length of thread for basic gauge length plus die clearance <i>L</i> mm	Thickness of hexagon <i>T</i> mm	Overall length <i>A</i> mm	Diameter of bore <i>C</i> mm		Width across flats of hexagon <i>B</i> mm
				Min.	Max.	
6	9,5	6	25	4,5	6,0	12,0
8	12,5	6	31	6,5	8,0	14,0
10	12,5	8	33	8,5	10,5	17,0
15	17,5	8	43	11,5	13,0	22,0
20	19,0	10	48	18,0	21,0	27,0
25	21,0	10	52	24,0	26,0	36,0
32	24,0	11	59	30,0	32,0	46,0
40	24,0	13	61	37,0	39,0	50,0
50	27,0	14	68	48,0	51,0	65,0
65	32,0	16	80	62,0	66,0	78,0
80	35,0	19	89	75,0	79,0	90,0
100	40,0	22	102	97,0	104,0	115,0
125	45,0	25	115	121,0	128,0	140,0
150	45,0	25	115	145,0	152,0	166,0

Table 15 - Hexagon bush

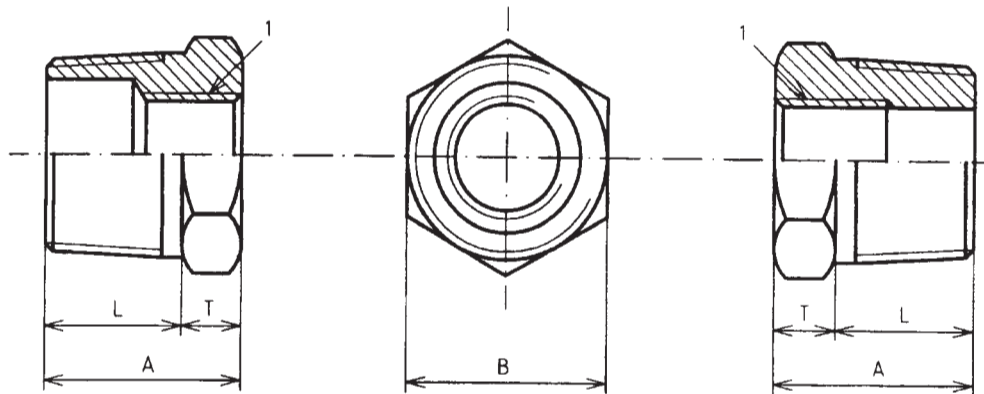

1 thread length in accordance with ISO 7-1.

Nominal size	Minimum length of external thread for basic gauge length plus die clearance	Thickness of hexagon	Overall length	Width across flats of hexagon
DN ¹⁾	<i>L</i>	<i>T</i>	<i>A</i>	<i>B</i>
	mm	mm	mm	mm
8	12,5	6	18,5	14,0
10	12,5	8	20,5	17,0
15	17,5	8	25,5	22,0
20	19,0	10	29,0	27,0
25	21,0	10	31,0	36,0
32	24,0	11	35,0	46,0
40	24,0	13	37,0	50,0
50	27,0	14	41,0	65,0
65	32,0	16	48,0	78,0
80	35,0	19	54,0	90,0
100	40,0	22	62,0	115,0
125	45,0	25	70,0	140,0
150	45,0	25	70,0	166,0

1) Nominal sizes refer to the size of male end, i.e the larger diameter of the bush. The smaller diameter of the bush is stated by the purchaser.

NOTE Two types of bush are illustrated, either of which can be supplied.

Table 16 - Square head plug

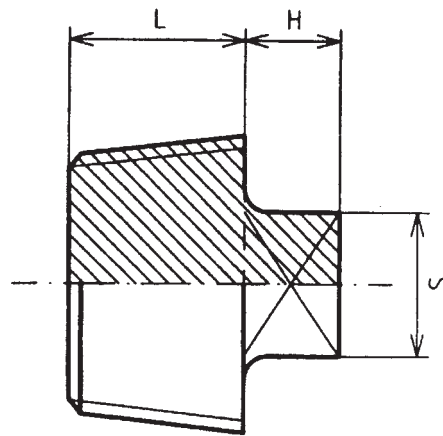

Nominal size	Minimum length of thread for basic gauge length	Size of square	Minimum height of square
DN	<i>L</i> mm	<i>S</i> mm	<i>H</i> mm
6 8 10	6,5 9,7 10,1	6 9 11	6 6 10
15 20 25	13,2 14,5 16,8	13 14 17	10 12 12
32 40 50	19,1 19,1 23,4	22 27 32	16 16 19
65 80 100	26,7 29,8 35,8	37 37 46	19 22 25
125 150	40,1 40,1	51 60	29 32

NOTE Plugs may be provided with a shallow concave recess in the base, so long as the essential solidity of the plug is maintained.

Table 17 - Hexagon head plug

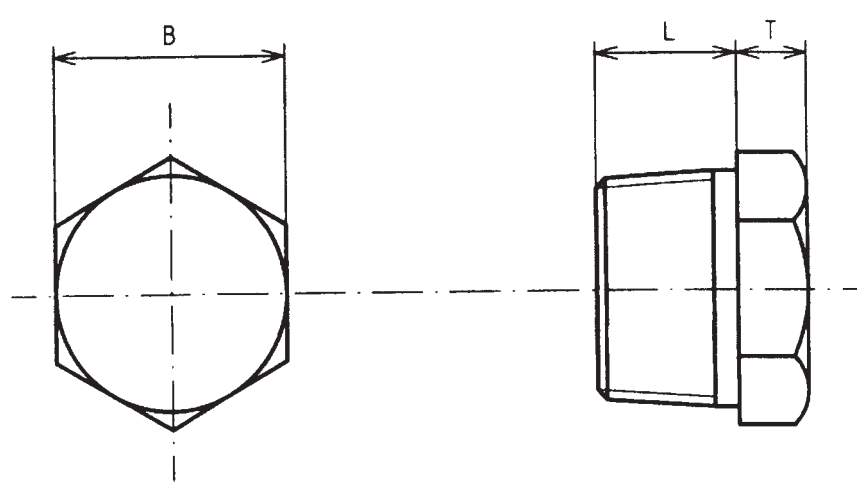

Nominal size DN	Minimum length of thread for basic gauge length plus die clearance <i>L</i> mm	Size of hexagon <i>B</i> mm	Minimum height of hexagon <i>T</i> mm
6 8 10	9,5 12,5 12,5	12 14 17	6 6 8
15 20 25	17,5 19,0 21,0	22 27 36	8 10 10
32 40 50	24,0 24,0 27,0	46 50 65	11 13 14
65 80 100	32,0 35,0 40,0	78 90 115	16 19 22

Table 18 - Socket union

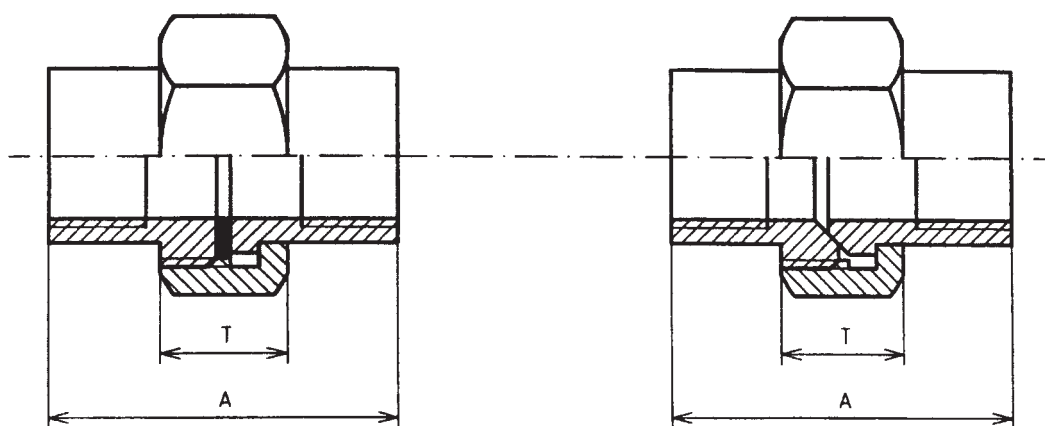

Socket union with flat seat

Socket union with taper seat

Nominal size DN	Overall length <i>A</i> mm	Length of nut <i>T</i> mm
6	37	15
8	40	15
10	46	16
15	51	18
20	57	20
25	64	22
32	70	24
40	79	25
50	89	27
65	102	30
80	107	31
100	118	34

CAUTION A socket union should only be used as complete assembly, because component parts of the union made by different manufacturers, or component parts of different types of union made by the same manufacturer, are not necessarily interchangeable.

NOTE Other external forms of nut and ends are permissible provided that the dimensions in tables are maintained.

Table 19 - Hexagon backnut

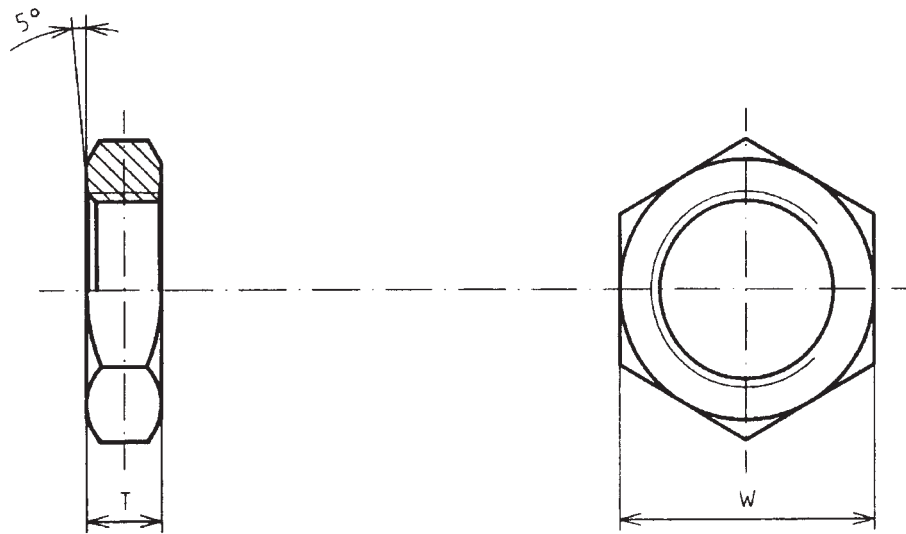

Nominal size DN	Width across flats $W^{1)}$ mm	Thickness	
		T mm	Tolerance mm
6 8 10	17,0 19,0 24,0	6,5 6,5 7,0	+ 1,5 0
15 20 25	30,0 36,0 41,0	8,0 9,0 9,5	
32 40 50	50,0 60,0 70,0	11,0 12,0 13,0	
65 80 100	90,0 100,0 130,0	17,0 21,0 22,0	+ 3,0 0
125 150	160,0 190,0	24,0 25,0	

1) The tolerance on width across the flat (w) is $\pm 0,8$ mm.

Table 20 - Cap

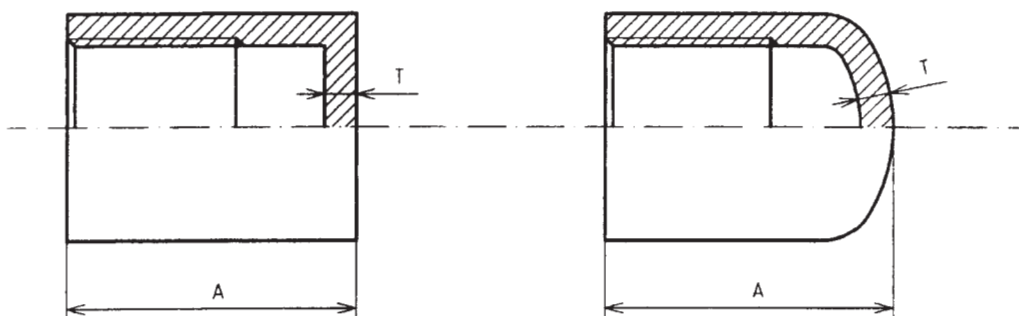

Nominal size DN	Overall length <i>A</i> mm	Minimum thickness <i>T</i> mm
6	19	3,5
8	24	3,5
10	27	3,5
15	37	4,0
20	38	4,0
25	44	4,5
32	51	5,0
40	54	5,5
50	60	6,0
65	67	6,0
80	73	7,0
100	86	7,0
125	98	7,5
150	98	8,5

NOTE A flat or domed cap may be supplied at the option of the manufacturer.

Table 21 - Longscrew

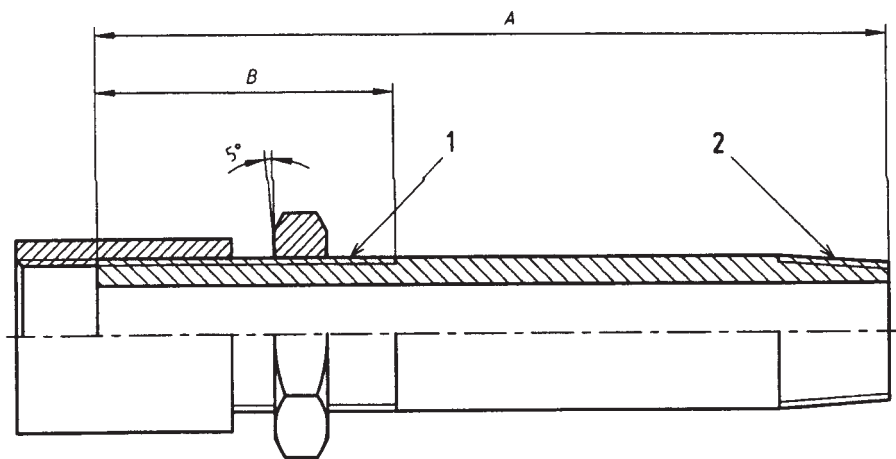

- 1 Parallel thread in accordance with ISO 7-1
- 2 Taper thread in accordance with ISO 7-1

Single longscrew

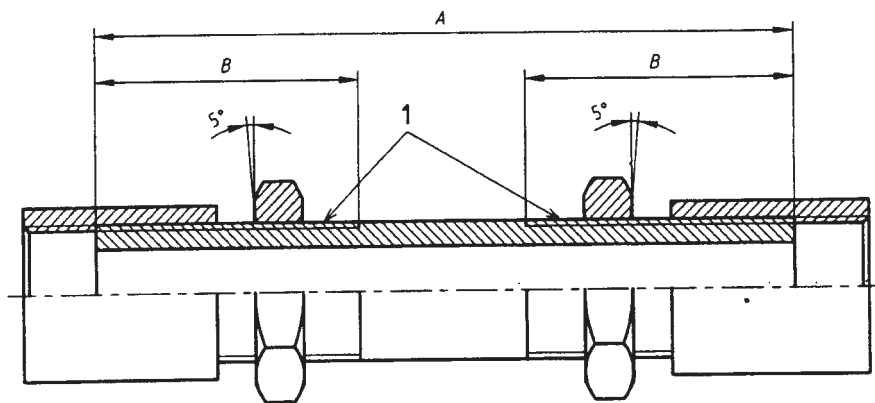

- 1 Parallel thread in accordance with ISO 7-1

Double longscrew

"to be continued"

Table 21 (continued)

Nominal size DN	Minimum useful length of the long thread <i>B</i> mm	Overall length <i>A</i> mm			
8 10	37 40	100 100 ¹⁾	150 150	200 200	250 250
15 20 25	52 54 62	100 ¹⁾ 100 ¹⁾ 100 ¹⁾	150 150 150	200 200 200	250 250 250
32 40 50	70 71 82	150 ¹⁾ 150 ¹⁾ 150 ¹⁾	200 200 200 ¹⁾	250 250 250	300 300 300
65 80 100	97 106 121	150 ¹⁾ 200 ¹⁾ 200 ¹⁾	250 ¹⁾ 250 ¹⁾ 250 ¹⁾	250 300 300	300 400 400
125 150	130 132	250 ¹⁾ 250 ¹⁾	300 ¹⁾ 300 ¹⁾	400 400	500 500

1) Double long screws cannot be supplied in these lengths.

CAUTION Long screws should only be used as complete assemblies because component parts of long screws made by the same or different manufacturers, are not necessarily interchangeable.

NOTE 1 The long screw parallel thread shall to be of such size, that the socket and backnut shall run on the long screw, hand-tight, without perceptible shake.

NOTE 2 The socket on the long screw shall abut the 5 degree angle of the backnut.

NOTE 3 Long screws shall be made only from heavy tube.

Table 22 - Pipe nipple

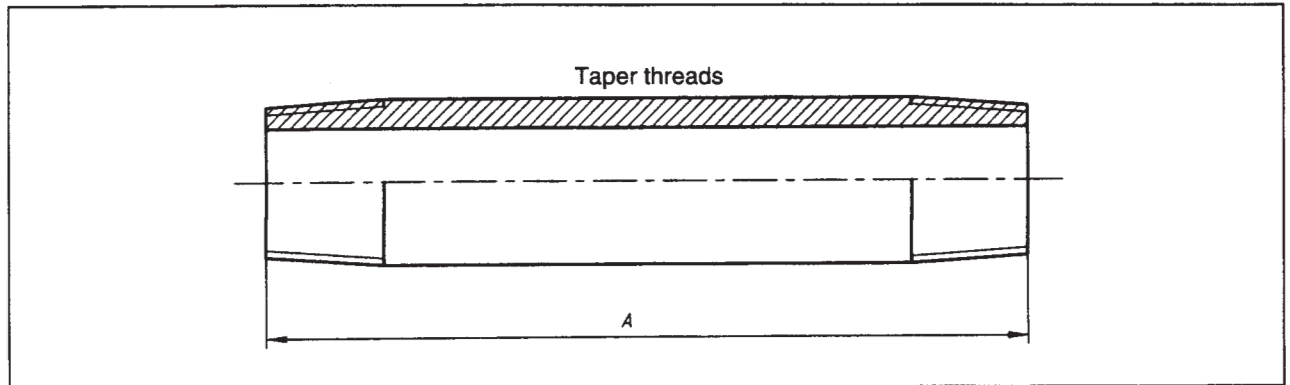

Nominal Size DN	Overall length A mm													
	30	40	50	60	80	100	120	150	180	200	250	300		
6 8 10	30 30 30	40 40 40	50 50 50	60 60 60	80 80 80	100 100 100	120 120 120	150 150 150	180 180 180	200 200 200	250 250 250	300 300 300		
15 20 25		40 40	50 50 50	60 60 60	80 80 80	100 100 100	120 120 120	150 150 150	180 180 180	200 200 200	250 250 250	300 300 300		
32 40 50			50 50	60 60 60	80 80 80	100 100 100	120 120 120	150 150 150	180 180 180	200 200 200	250 250 250	300 300 300		
65 80 100					80 80	100 100 100	120 120 120	150 150 150	180 180 180	200 200 200	250 250 250	300 300 300	400 400	
125 150							120 120	150 150	180 180	200 200	250 250	300 300	400 400	500 500

Table 23 - Running nipple, close nipple and barrel nipple

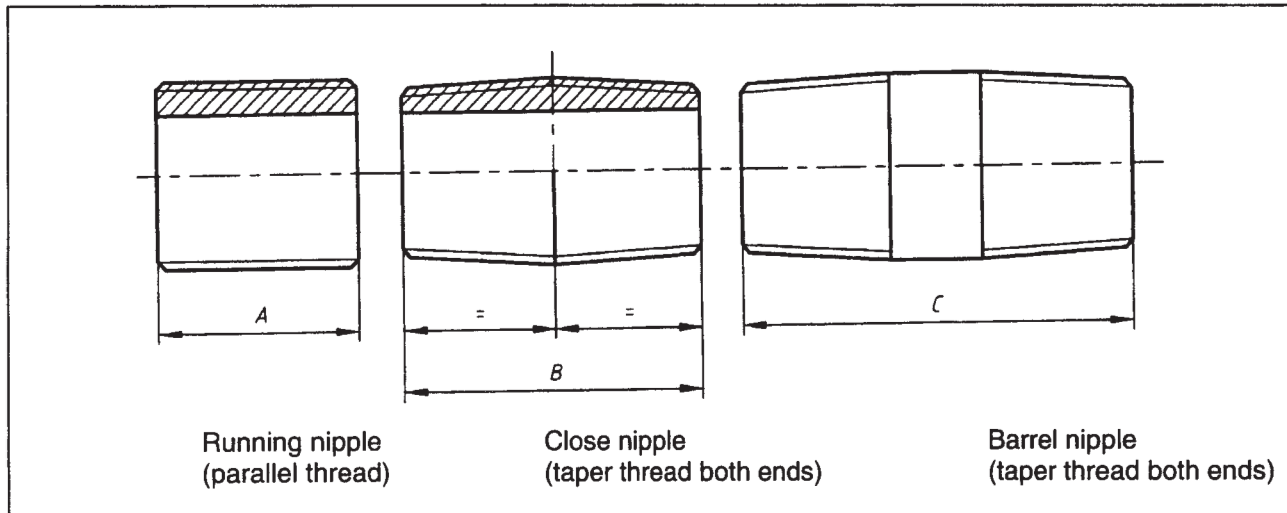

Nominal size DN	Overall length					
	Running nipple		Close nipple		Barrel nipple	
	A mm	Tolerance mm	B mm	Tolerance mm	C mm	Tolerance mm
8	19	+ 1,5	27	+ 1,5	38	+ 3
10	21		28		38	
15	27		37		51	
20	30	+ 1,5	39	+ 1,5	54	+ 4,5
25	33		46		60	
32	38	+ 1,5	51	+ 1,5	70	+ 6
40	38		51		70	
50	48	+ 3	60	+ 3	79	+ 8
65	51		69		89	
80	57		75		102	
100	70		87		114	
125	78		96		124	
150	78	96	96	127		

Table 24 - Bend and spring

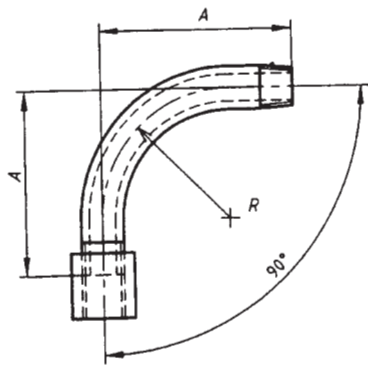

Type 1

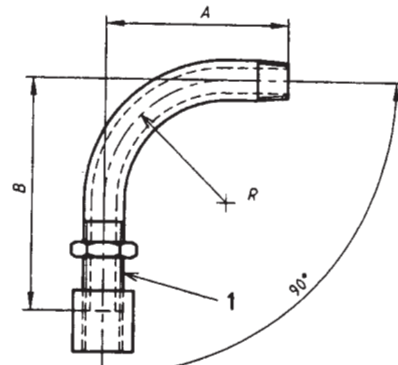

1 Parallel thread length as for long screw
Type 1A

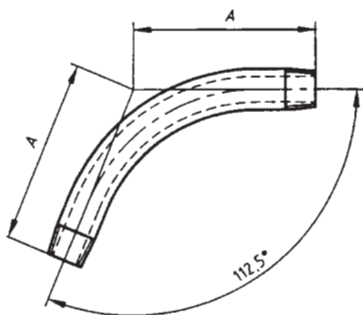

Type 2

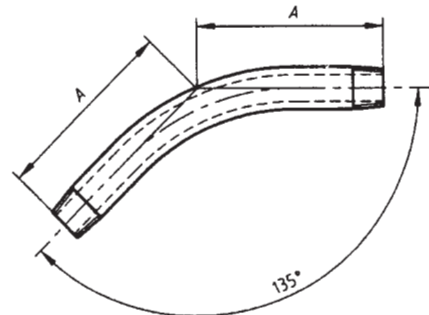

Type 3

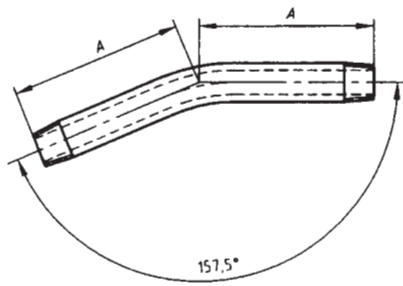

Type 4

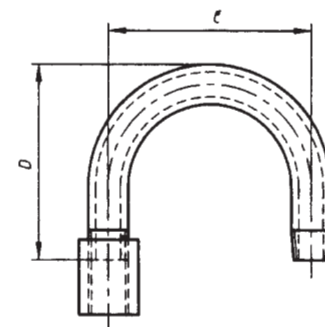

Return bend

"to be continued"

Table 24 (continued)

Nominal Size	Bend			Spring			Return bend	
	90 °			Centre to face			180 °	
	Centre to face		Radius	A mm			Centre to centre	Back to face
	A	B	R	112,5°	135°	157,5°	C	D
DN	mm	mm	mm				mm	mm
8	64	92	41	60	57	54	51	64
10	73	105	48	67	64	60	64	70
15	86	127	57	79	76	73	89	102
20	102	143	73	92	89	86	102	121
25	121	168	89	108	105	102	114	140
32	146	197	108	133	127	124	127	152
40	165	219	127	149	143	140	165	178
50	203	264	159	181	175	168	190	210
65	248	321	197	222	213	206	305	292
80	292	371	232	260	248	241	356	330
100	381	467	308	340	324	318	457	400
125	540	632	380	476	457	444	762	578
150	622	718	440	572	540	527	914	692

- NOTE 1 Type 1A bend shall only be made from heavy tube (see table 6) and fitted with socket and backnut.
- NOTE 2 The angular tolerance shall be as defined in 7.2.3.
- NOTE 3 All threads are taper except where shown above.
- NOTE 4 The end of type 1A bend with parallel thread shall be manufactured in accordance with notes 1 and 2 of table 21.

Annex A (informative)

Thread designation and nominal size

Table A.1 - Thread designation and nominal size

Nominal size DN	Designation of thread size/fitting size
6	1/8
8	1/4
10	3/8
15	1/2
20	3/4
25	1
32	1 1/4
40	1 1/2
50	2
65	2 1/2
80	3
100	4
125	5
150	6